

**745 Down-Send Remote System  
Installation and Operation Manual  
January 01, 2024**



**Model 745 Down-Send**



## **TABLE OF CONTENTS**

### **DISCLAIMER**

### **WARNINGS**

## **1 INTRODUCTION**

- 1.1 Product Overview
- 1.2 General Specification
- 1.3 Teller Terminal Specification (Figure 1-1 Dwg# 20167 sheet 2 Of 6 )
- 1.4 Customer Terminal Specification (Figure 1-2 Dwg# 20167 sheet 3 Of 6 )

## **2 INSTALLATION**

- 2.1 Unpacking Instructions (Figure 1-3 Dwg# 20167 sheet 1 of 6 )
- 2.2 Site Requirements
- 2.3 Installation Procedure
- 2.4 Wiring Diagrams
  - Figure 2-1 (Dwg # 20167 sheet 4 Of 6 )
  - Figure 2-2 (Dwg # 20167 sheet 5 Of 6 )
  - Figure 2-3 (Dwg # 20167 sheet 6 Of 6 )
- 2.5 Installation Drawings
  - Figure 2-4 (Dwg. # 20167-01 )

## **3 OPERATION**

- 3.1 Switches and Indicators
- 3.2 Functions
- 3.3 Sequence of Operation

## **4 MAINTENANCE**

- 4.1 Cleaning
- 4.2 Preventative Maintenance

## **5 SERVICE**

- 5.1 Fault Analysis
- 5.2 Pre-requisite vs. Stand-alone functions
- 5.3 Field Wiring
- 5.4 Troubleshooting Guide



## DISCLAIMER

The material in this manual is for information purposes only. The contents and the product described are subject to change without notice. The manufacturer makes no presentations or warranties with respect to this manual. This product was designed for certain applications only. It may not be modified and/or used for any applications other than that which it was designed. The design specifications of the product described herein is subject to change without notice. The manufacturer reserves the right to make such changes without incurring any obligation to make them in units previously sold. Differences between the unit you received and the views contained herein are the result of design improvement and/or the addition of options as specified.

## WARNINGS

**Caution:** If not properly installed, operated and maintained, the use of this equipment presents the possibility of personal injury or property damage. Before use, all persons who will install, operate or maintain this product should read this manual thoroughly. For safe, dependable performance, follow all instructions and recommendations contained herein.

**Caution:** To prevent fire or shock, do not expose this product to rain or any type of moisture.

**Caution:** Keep hands clear of moving parts.

**Caution:** Always unplug unit from power source prior to cleaning or servicing unit.

## 1 INTRODUCTION

### 1.1 Product overview

This pneumatic tube system is a durable, field proven unit. It has been designed to provide easy access by both customer and teller, and reliable operation under harsh conditions.

This pneumatic tube system is for overhead tube applications using the proven push-pull method. Blowers are located in the customer unit and insulated for quiet operation.

### 1.2 Specifications

Power Requirements:	120 VAC 50/60 Hz.	20 Amp Circuit
Power Consumption	Kiosk:	2 Amp
	Blowers:	9 Amps ea.
Maximum package weight:	No more than 4 roll of coins, otherwise limited only by space in carrier.	
Maximum carrier velocity:	40 feet per second	

### 1.3 Using This Manual

TU refers to the Teller Unit Assembly part number 745 DTU

CU refers to the Customer Unit Assembly part number 745 CTU

PCB refers to Printed Circuit Board

RTS refers to Remote Teller System

## 2 INSTALLATION

### 2.1 Unpacking and Inspection

The carton should contain the following items:

- 1 Teller Terminal Assembly
- 1 Customer Terminal Assembly
- 1 Counter Mount Bracket
- 1 TU Leveler Mount Bracket
- 4 TU Leveler
- 1 CU Mounting Base
- 4 CU Leveler
- 5 Plug, Terminal Block, 8 pos.
- 2 Carrier, Clr/Clr/All 4.29
- 4 Screw, Truss Head, Phillips, ¼-20 x ¾ S.S.
- 2 Screw Hex Washer, Thread Cutting, 8-32 x 5/8
- 4 Wedge Anchor, ¼" x 3-1/2"
- 4 Hex Nut, ¼-20
- 4 Kep Nut, 8-32
- 4 Flat Washer, #8
- 1 Steel Tubing, 4-1/2" x 24" lg.
- 4 Coupling, 4-1/2" x 6"
- 1 Manual, 745DD Downsend RTS

### 2.2 Site Requirements

The pneumatic tube system can be installed in most existing drive thru locations. It is recommended that the Customer Unit be under a canopy to protect it from the weather.

Electrical power uses 3 ea. 3/4" conduits. One for 115 VAC power, One for 745 System control cable and one for, CCTV and audio. Each lane must have (1) 20 amp circuit. This circuit supplies both the customer kiosk and the teller kiosk. The TU can plug into a duplex outlet dedicated to that lane and the customer unit should be direct wired by an Electrician. It is recommended that each lane, inclusive of the 745 TU and CU be on a single 20 Amp Double pole wall switch so the unit can be powered down when not in use. These are frequently located near the Lane Light Switches for convenience.

Note: Reference section 2.5 for the Installation Drawing.

### 2.3 Installation Procedure

#### 2.3.1 Underground Tubing (Pre-existing)

Pressure testing

Visual Inspection

#### 2.3.2 Underground Tubing (New Installation)

Pressure testing

Visual Inspection

#### 2.3.3 Teller Unit Installation (DownSend)

Refer to Fig. 2-1 (Drawing 20167 Sheet 2 of 6) for TU installation Details.

#### 2.3.4 Customer Unit Installation

Refer to Fig. 2-2 (Drawing 20167 Sheet 3 of 6) for TU installation Details.

NOTES:

1. SPECIFY AUDIO SET-UP. (EX: AUDIO AUTHORITY).
2. CUSTOMER UNIT WILL ACCEPT CAMERA AND/OR DISPLAY. ORDER SEPERATELY.
3. TUBE IS CUT TO LENGTH AS REQUIRED FOR TRANSITION OF UNDERGROUND TUBING TO CARRIER TUBE INSIDE TELLER & CUSTOMER UNIT.

745 SERIES TUBE SYSTEM



BANK EQUIPMENT AS TO ELECTRICAL FIRE, SHOCK AND CASUALTY HAZARDS ONLY IN ACCORDANCE WITH STANDARD UL 60950-1 80NN

E216338

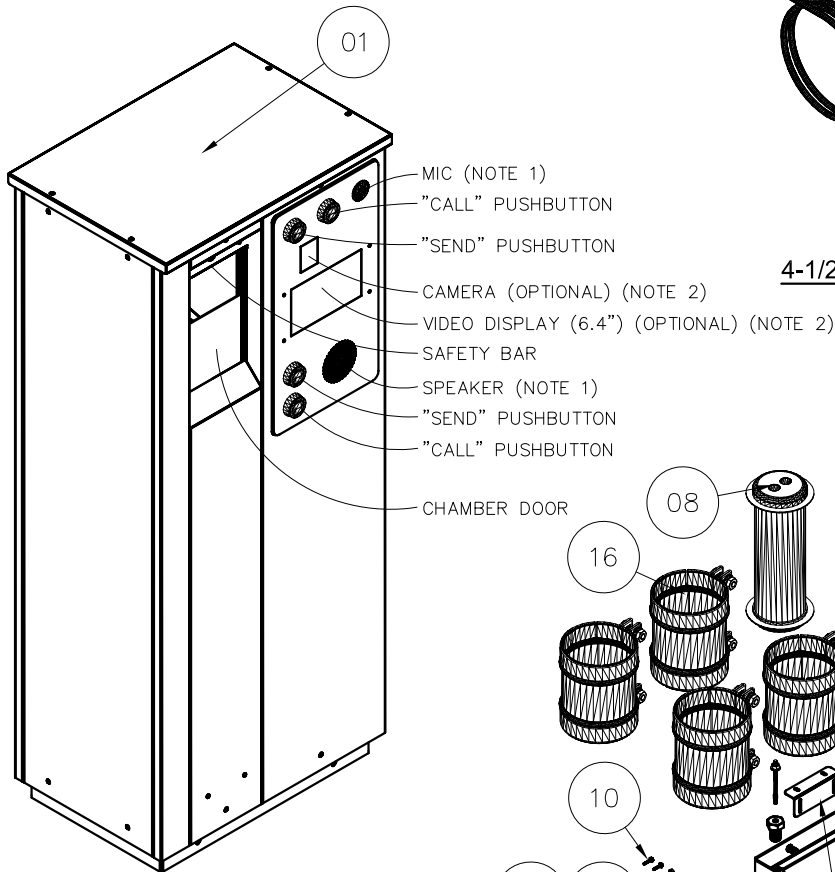

**MODEL 745DCU**  
**4-1/2" DOWNSEND CUSTOMER UNIT**  
**SHOWN**

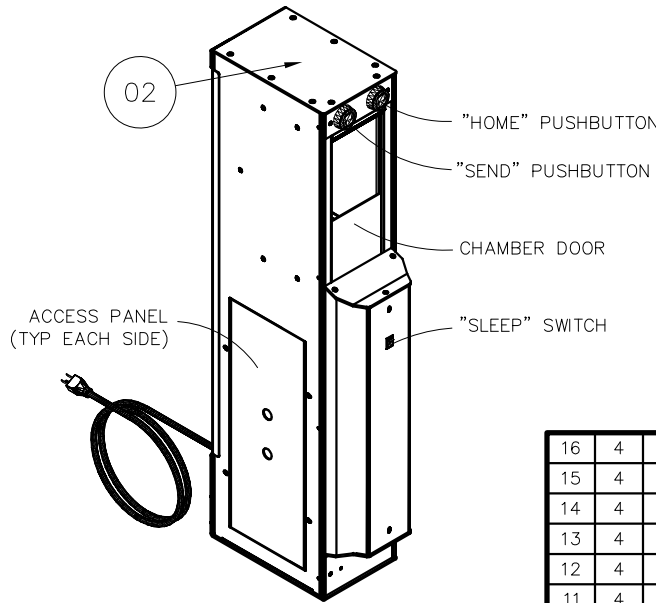

**MODEL 745DTU**  
**4-1/2" DOWNSEND TELLER UNIT**

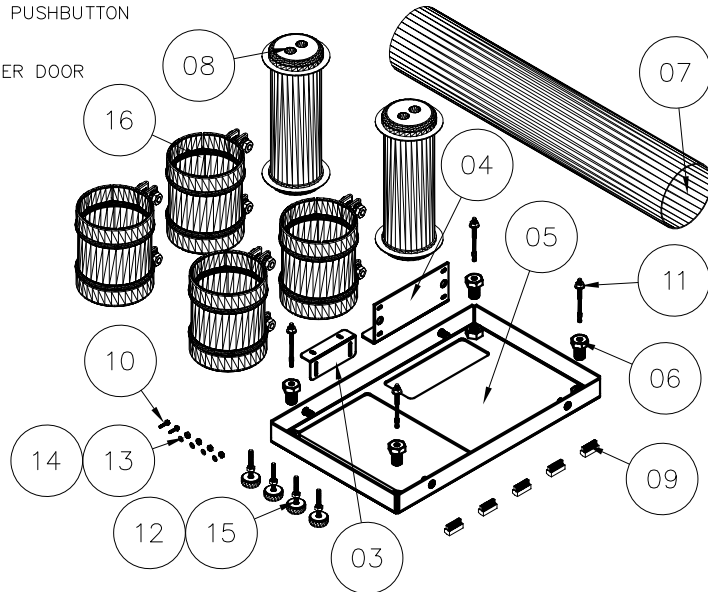

SYSTEM MODEL NUMBER DESCRIPTIONS

SYSTEM MODEL 745DDS  
1ea. MODEL 745DTU 4-1/2" DOWNSEND TELLER UNIT  
1ea. MODEL 745DCUS 4-1/2" DOWNSEND CUSTOMER UNIT WITH 6" TO 9" RECOMMENDED TUBE SETBACK.

SYSTEM MODEL 745DDM  
1ea. MODEL 745DTU 4-1/2" DOWNSEND TELLER UNIT  
1ea. MODEL 745DCUM 4-1/2" DOWNSEND CUSTOMER UNIT WITH 10" TO 13" RECOMMENDED TUBE SETBACK.

SYSTEM MODEL 745DDX  
1ea. MODEL 745DTU 4-1/2" DOWNSEND TELLER UNIT  
1ea. MODEL 745DCUX 4-1/2" DOWNSEND CUSTOMER UNIT WITH 18" TO 21" RECOMMENDED TUBE SETBACK.

ITEM	QTY	MODEL/PART	DESCRIPTION	NOTE
16	4	9030-0009	COUPLING, 4-1/2" x 6" INSTALOCK	
15	4	8400-0004	LEVELER 1/4-20x2-1/2	
14	4	8180-0118	WASHER FLAT #8 SS	
13	4	8160-3214	NUT KEP 8-32 Z	
12	4	8150-3225	NUT HEX 1/4-20 Z	
11	4	8097-0002	ANCHOR, WEDGE 1/4x3-1/4	
10	2	8055-3620	HWHTCS 8-32x5/8 F Z	
09	5	7428-0008	PLUG, 8 POS TERM BLOCK	
08	2	4001-77AF	CARRIER, CLAM SHELL 4.29 DISC	
07	1	745-9798	TUBE, 4-1/2" x 24" STEEL	3
06	4	745-9790	MOUNT, LEVELER	
05	1	745-9751	BASE, CU MOUNTING	
04	1	745-9735	MOUNT, LEVELER	
03	1	745-9732	BRACKET, COUNTER MOUNT	
02	1	745DTU	TELLER UNIT 4-1/2" DOWNSEND	3
01	1	745DCU	CUSTOMER UNIT 4-1/2" DOWNSEND	1,2,3
<b>SYSTEM COMPONENTS</b>				

DO NOT SCALE

**American Vault**<sup>®</sup> Waco Texas

PRODUCT APPLICATION DRAWING  
MODEL 745DD 4-1/2" DOWNSEND REMOTE SYSTEM  
(DOWNSEND TU to DOWNSEND CU)

SIZE	DWG NO	DATE	SHEET
<b>A</b>	20167	12.01.2023	1 OF 6

OWNER'S ELECTRICAL CONTRACTOR TO PROVIDE 120 VAC, 60 HZ, SINGLE PHASE, 20 AMP DEDICATED BRANCH CIRCUIT w/OPTIONAL DUPLEX OUTLET. (1) CIRCUIT PER SYSTEM. TELLER UNIT AND CUSTOMER UNIT ON SAME CIRCUIT.

CONTROL CABLE CONDUIT (3/4") FROM CUSTOMER UNIT

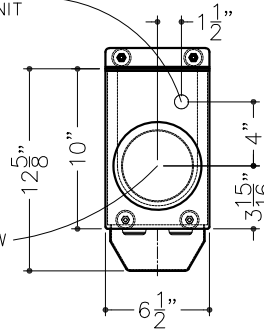

TUBE CENTER BELOW

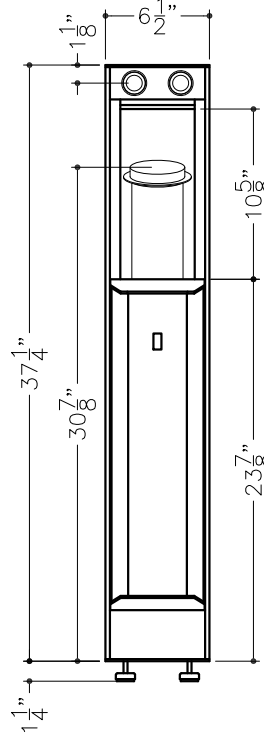
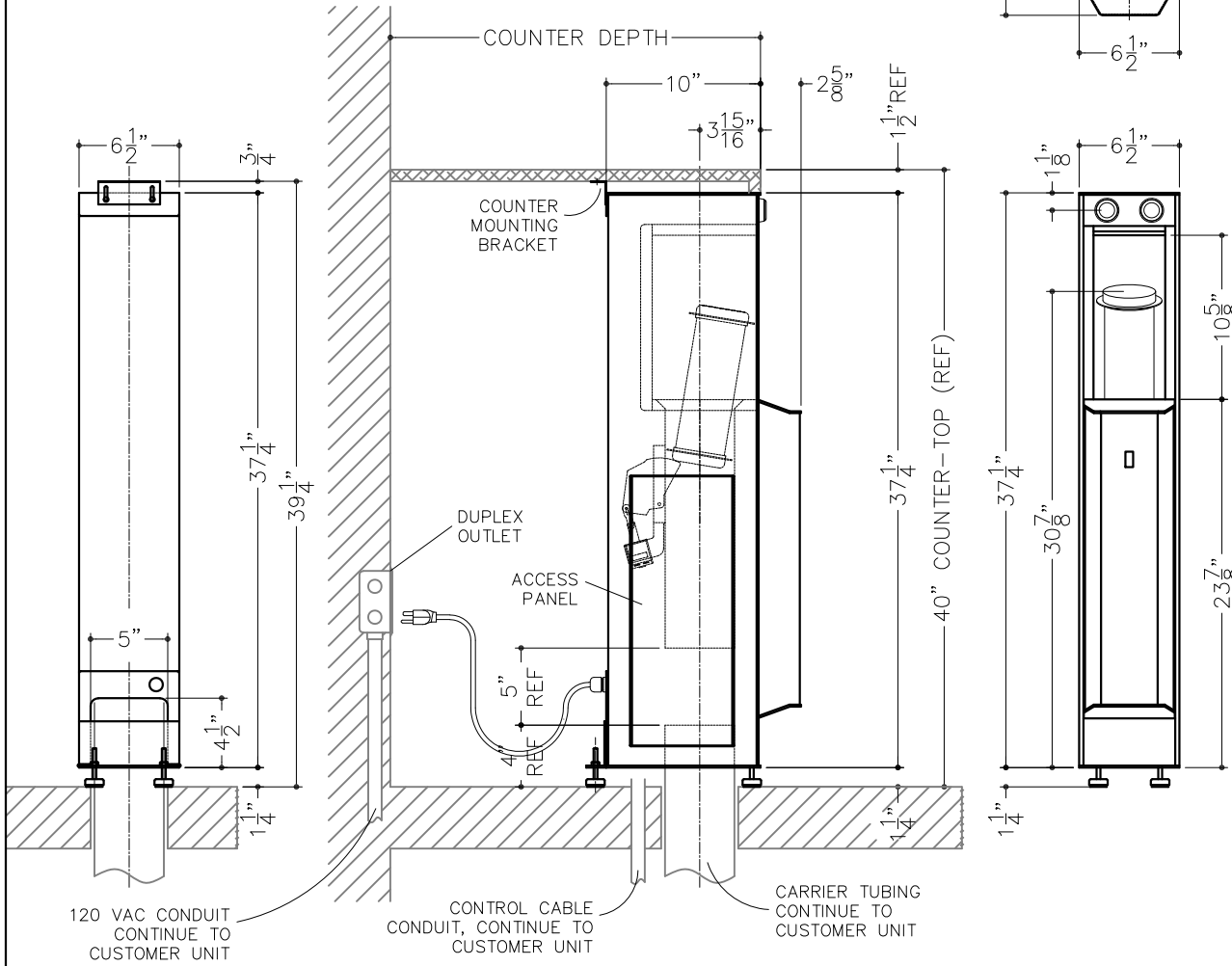

**TELLER UNIT (TU) CONTROLS**

**"SEND" PUSHBUTTON**

WHEN PRESSED THE TU DOOR CLOSES & CARRIER IS SENT TO THE CU. UPON ARRIVAL AT THE CU THE CARRIER CHAMBER DOOR OPENS TO PRESENT THE CARRIER.

**"HOME" PUSHBUTTON**

WHEN PRESSED THE CU CARRIER CHAMBER DOOR CLOSES AND CARRIER IS RETRIEVED FROM THE CU. UPON ARRIVAL AT THE TU, CARRIER CHAMBER DOOR OPENS TO PRESENT THE CARRIER.

**"SLEEP" SWITCH**

WHEN SWITCHED "ON" (RED INDICATOR IS LIT) THE CU & TU DOORS CLOSE AND SYSTEM IS NO LONGER OPERABLE. WHEN SWITCHED "OFF" THE SYSTEM IS ENABLED FOR NORMAL FUNCTIONS.

**TYPICAL TRANSACTION**

CUSTOMER ARRIVES AT THE CUSTOMER UNIT WITH THE CARRIER IN THE CARRIER CHAMBER. THE CUSTOMER REMOVES THE CARRIER AND PLACES TRANSACTION INSIDE CARRIER. CUSTOMER THEN INSERTS CARRIER IN THE CARRIER CHAMBER AND PASSES "SEND" BUTTON. THE CARRIER DROPS INTO THE TUBE AS THE CARRIER CHAMBER DOOR CLOSES. WHEN THE DOOR HAS FULLY CLOSED THE AIR HANDLER WILL ENERGIZE AND DELIVER THE CARRIER TO THE TELLER UNIT. THE CARRIER WILL THEN PRESENT ITSELF AS THE TELLER UNIT CHAMBER DOOR OPENS. OPERATOR THEN RETRIEVES THE CARRIER.

TO COMPLETE THE TRANSACTION OPERATOR INSERTS CARRIER INTO TELLER UNIT CHAMBER AND PASSES "SEND" BUTTON. THE CARRIER THEN DROPS INTO THE TUBE AS THE CARRIER CHAMBER DOOR CLOSES. WHEN THE DOOR HAS FULLY CLOSED THE AIR HANDLER WILL ENERGIZE AND DELIVER THE CARRIER TO THE CUSTOMER UNIT.

DO NOT SCALE

**American Vault**® Waco Texas

PRODUCT APPLICATION DRAWING  
**MODEL 745DD 4-1/2" DOWNSEND REMOTE SYSTEM**  
 (MODEL 745 DOWNSEND TU DETAILS)

SIZE	DWG NO	DATE	SHEET
<b>A</b>	20167	12.01.2023	2 OF 6

**CUSTOMER UNIT (CU) CONTROLS**

**"SEND" PUSHBUTTON**

WHEN PRESSED THE CARRIER CHAMBER DOOR CLOSES AND CARRIER IS SENT TO THE TU. UPON ARRIVAL AT THE TU THE CARRIER CHAMBER DOOR OPENS TO PRESENT THE CARRIER.

**"CALL" PUSHBUTTON**

WHEN A CUSTOMER ARRIVES AT THE CU THE CUSTOMER MAY PRESS THE "CALL" BUTTON. THIS ACTIVATES AN AUDIO CHIME ON THE TELLER STATION AUDIO TO ALERT THE OPERATOR THAT A CUSTOMER WISHES TO COMMUNICATE.

OWNER'S ELECTRICAL CONTRACTOR TO PROVIDE 120 VAC, 60 HZ, SINGLE PHASE, 20 AMP DEDICATED BRANCH CIRCUIT w/OPTIONAL DUPLEX OUTLET. (1) CIRCUIT PER SYSTEM. TELLER UNIT AND CUSTOMER UNIT ON SAME CIRCUIT.

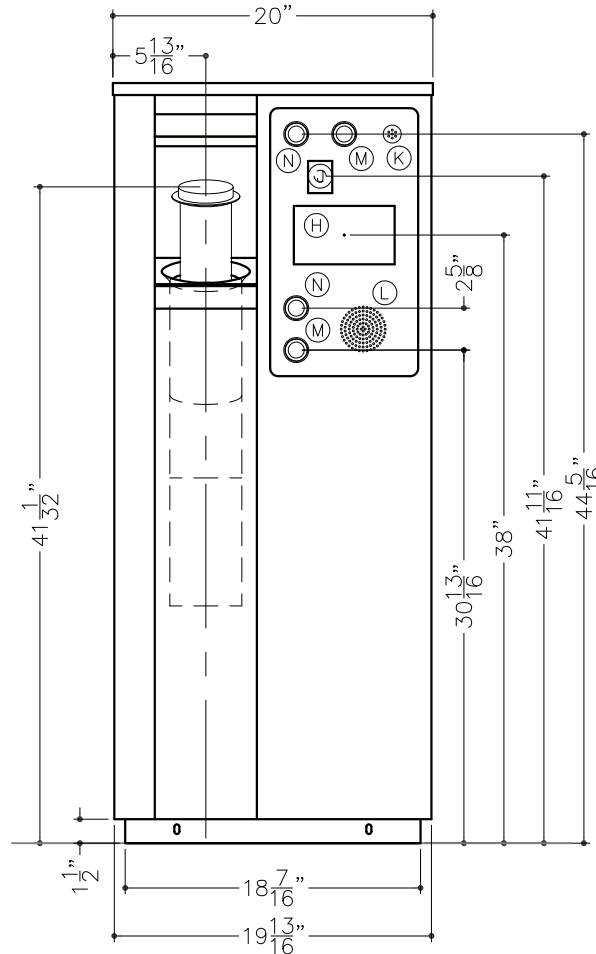
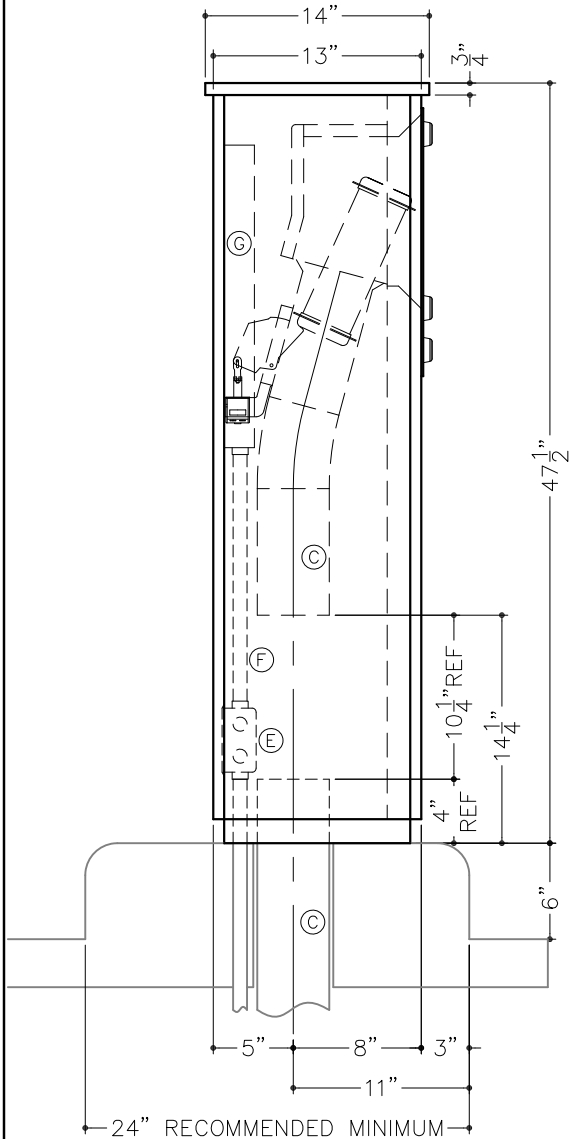

**MODEL 745DCUM**  
**4-1/2" DOWNSEND CUSTOMER UNIT**  
**10" TO 13" RECOMMENDED**  
**TUBE SETBACK**

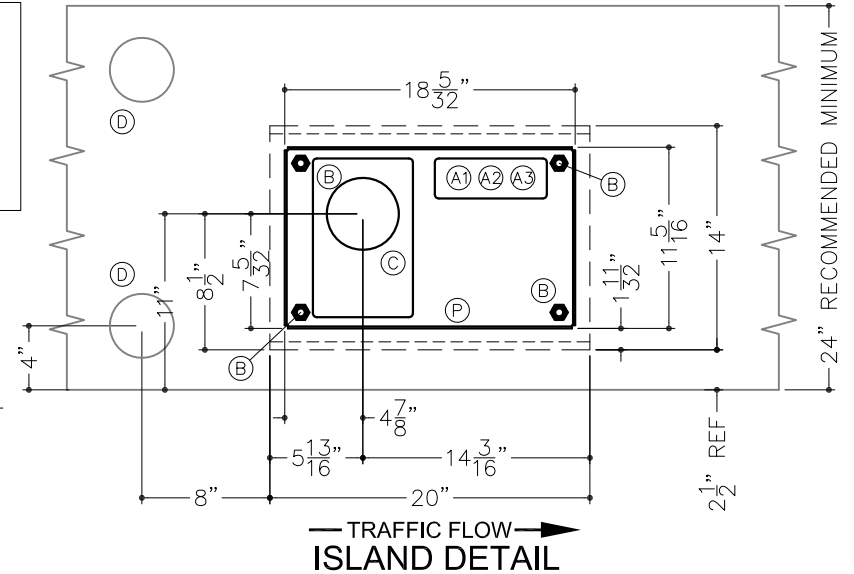

- LEGEND:
- A 3/4" CONDUIT (3x)
  - A1 120 Vac, 60 HZ, SINGLE PHASE 20AMP DEDICATED CIRCUIT
  - A2 AUDIO/VIDEO CONDUIT FROM AUDIO/VIDEO HUB
  - A3 CONTROL CABLE FROM TELLER UNIT.
  - B COMBINATION LEVELING BOLT & ANCHOR (4x)
  - C 4-1/2" CARRIER TUBE
  - D BOLLARD
  - E DUPLEX OUTLET FOR CONVENIENCE(OPTIONAL)
  - F CONDUIT FROM OUTLET
  - G CONTROL PANEL
  - H VIDEO DISPLAY (OPTIONAL)
  - J CAMERA (OPTIONAL)
  - K AUDIO MICROPHONE
  - L AUDIO SPEAKER
  - M "CALL" BUTTON (2x)
  - N "SEND" BUTTON (2x)
  - P CUSTOMER UNIT MOUNTING BASE

DO NOT SCALE



PRODUCT APPLICATION DRAWING  
**MODEL 745DD 4-1/2" DOWNSEND REMOTE SYSTEM**  
 (MODEL 745DCUM 4-1/2" DOWNSEND CUSTOMER UNIT DETAILS)  
 (10" to 13" RECOMMENDED TUBE SETBACK)

SIZE	DWG NO	DATE	SHEET
<b>A</b>	20167	12.01.2023	3 OF 6

**CUSTOMER UNIT (CU) CONTROLS**

**"SEND" PUSHBUTTON**

WHEN PRESSED THE CARRIER CHAMBER DOOR CLOSES AND CARRIER IS SENT TO THE TU. UPON ARRIVAL AT THE TU THE CARRIER CHAMBER DOOR OPENS TO PRESENT THE CARRIER.

**"CALL" PUSHBUTTON**

WHEN A CUSTOMER ARRIVES AT THE CU THE CUSTOMER MAY PRESS THE "CALL" BUTTON. THIS ACTIVATES AN AUDIO CHIME ON THE TELLER STATION AUDIO TO ALERT THE OPERATOR THAT A CUSTOMER WISHES TO COMMUNICATE.

OWNER'S ELECTRICAL CONTRACTOR TO PROVIDE 120 VAC, 60 HZ, SINGLE PHASE, 20 AMP DEDICATED BRANCH CIRCUIT w/OPTIONAL DUPLEX OUTLET. (1) CIRCUIT PER SYSTEM. TELLER UNIT AND CUSTOMER UNIT ON SAME CIRCUIT.

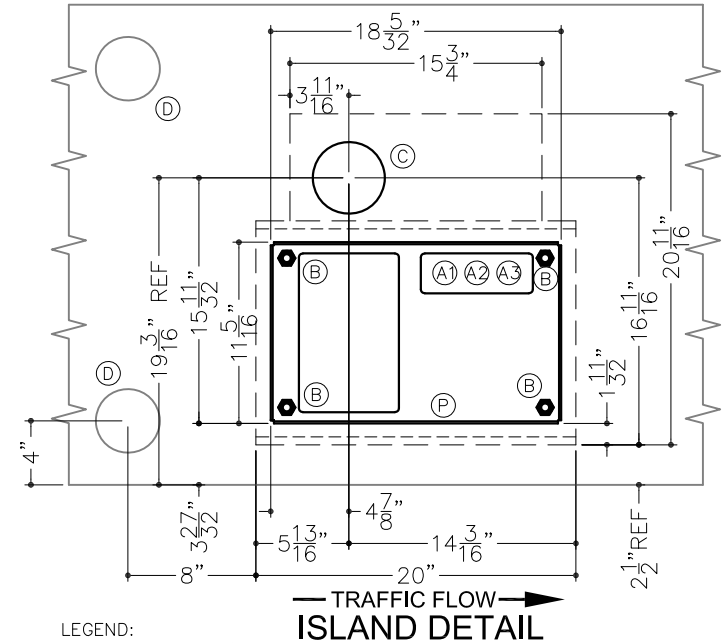
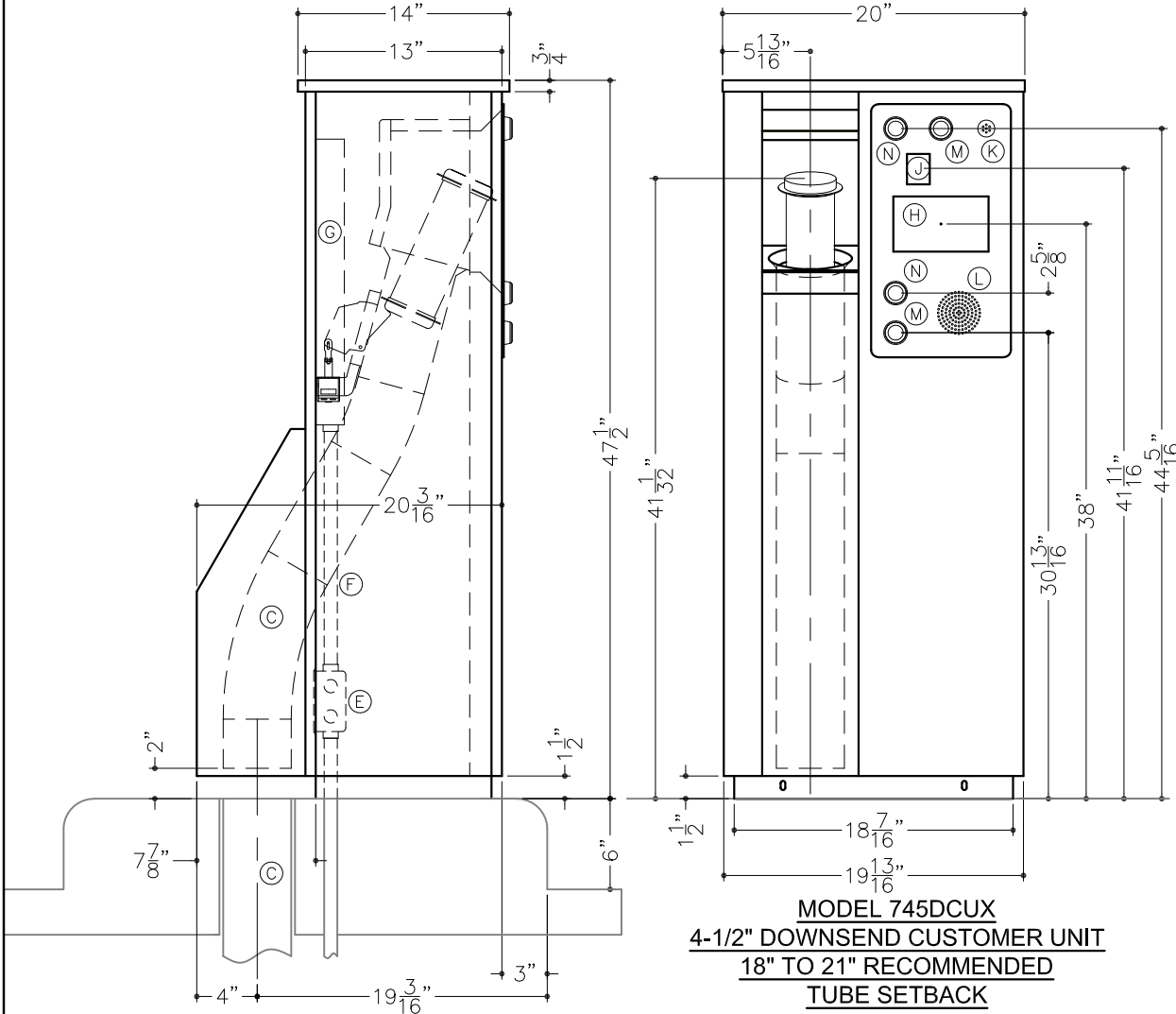

**LEGEND:**

- A 3/4" CONDUIT (3x)
- A1 120 Vac, 60 HZ, SINGLE PHASE 20AMP DEDICATED CIRCUIT
- A2 AUDIO/VIDEO CONDUIT FROM AUDIO/VIDEO HUB
- A3 CONTROL CABLE FROM TELLER UNIT.
- B COMBINATION LEVELING BOLT & ANCHOR (4x)
- C 4-1/2" CARRIER TUBE
- D BOLLARD
- E DUPLEX OUTLET FOR CONVENIENCE(OPTIONAL)
- F CONDUIT FROM OUTLET
- G CONTROL PANEL
- H VIDEO DISPLAY (OPTIONAL)
- J CAMERA (OPTIONAL)
- K AUDIO MICROPHONE
- L AUDIO SPEAKER
- M "CALL" BUTTON (2x)
- N "SEND" BUTTON (2x)
- P CUSTOMER UNIT MOUNTING BASE

**DO NOT SCALE**

**American Vault®** Waco Texas

PRODUCT APPLICATION DRAWING  
**MODEL 745DD 4-1/2" DOWNSEND REMOTE SYSTEM**  
**(MODEL 745DCUX CUSTOMER UNIT DETAILS)**  
**(18" to 21" RECOMMENDED TUBE SETBACK)**

SIZE	DWG NO	DATE	SHEET
<b>A</b>	20167	12.01.2023	4 OF 6



## CUSTOMER UNIT (CU) CONTROLS

### "SEND" PUSHBUTTON

WHEN PRESSED THE CARRIER CHAMBER DOOR CLOSES AND CARRIER IS SENT TO THE TU. UPON ARRIVAL AT THE TU THE CARRIER CHAMBER DOOR OPENS TO PRESENT THE CARRIER.

### "CALL" PUSHBUTTON

WHEN A CUSTOMER ARRIVES AT THE CU THE CUSTOMER MAY PRESS THE "CALL" BUTTON. THIS ACTIVATES AN AUDIO CHIME ON THE TELLER STATION AUDIO TO ALERT THE OPERATOR THAT A CUSTOMER WISHES TO COMMUNICATE.

OWNER'S ELECTRICAL CONTRACTOR TO PROVIDE 120 VAC, 60 HZ, SINGLE PHASE, 20 AMP DEDICATED BRANCH CIRCUIT w/OPTIONAL DUPLEX OUTLET. (1) CIRCUIT PER SYSTEM. TELLER UNIT AND CUSTOMER UNIT ON SAME CIRCUIT.

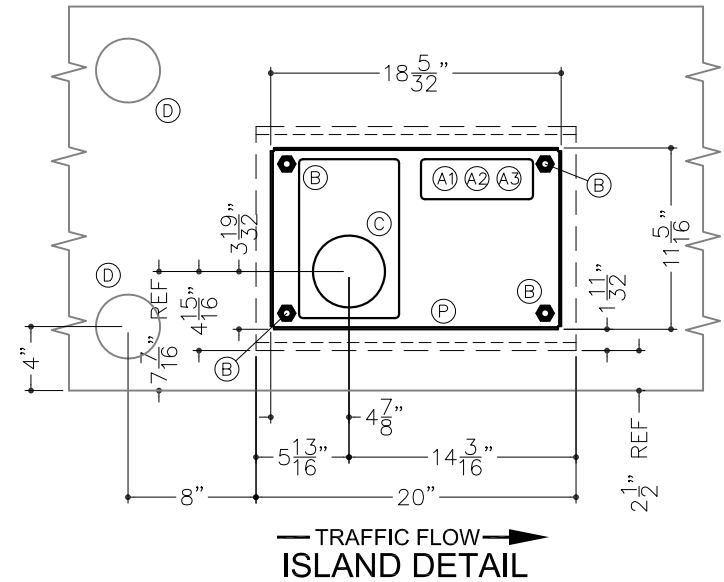
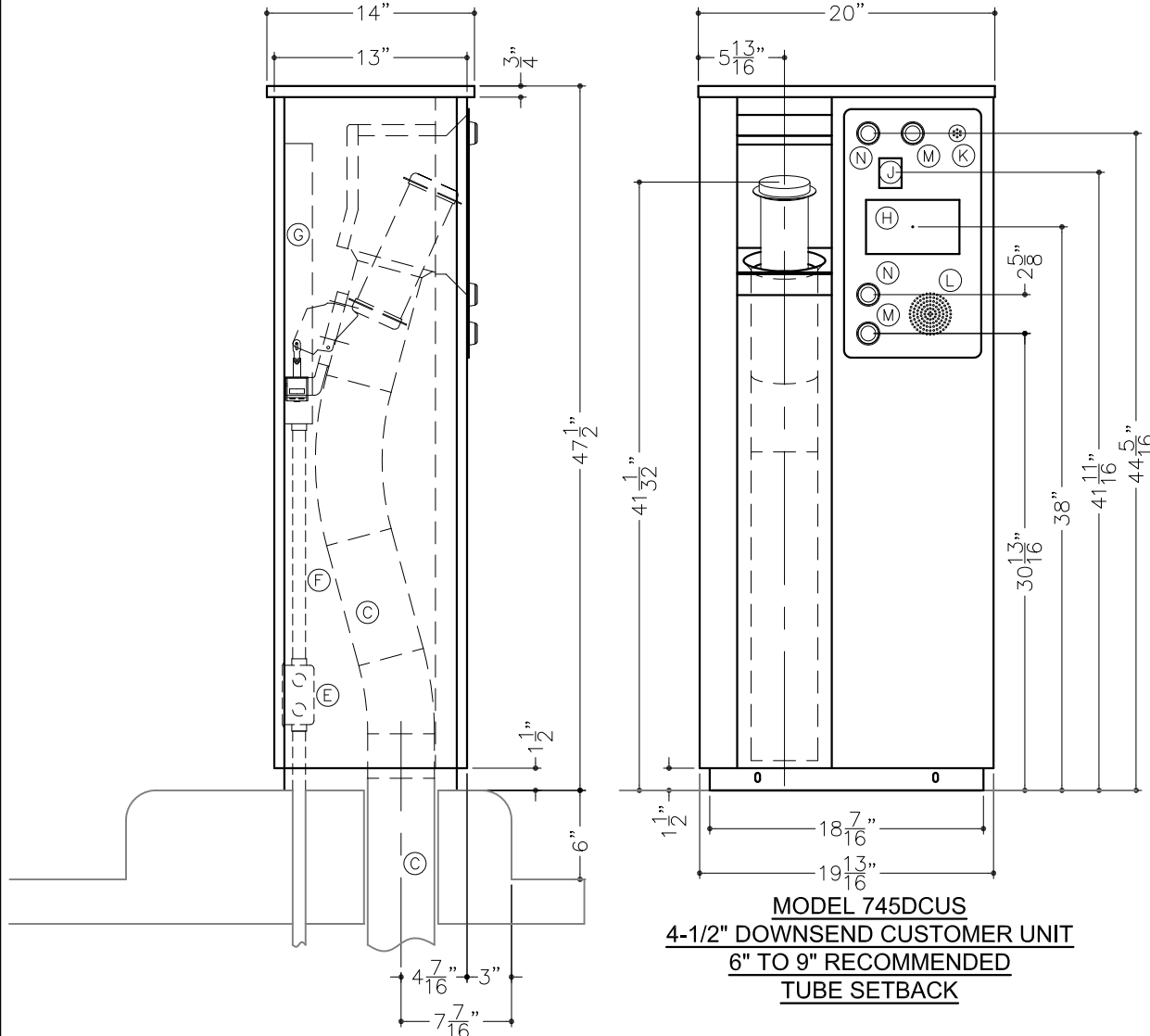

#### LEGEND:

- A 3/4" CONDUIT (3x)
- A1 120 Vac, 60 HZ, SINGLE PHASE 20AMP DEDICATED CIRCUIT
- A2 AUDIO/VIDEO CONDUIT FROM AUDIO/VIDEO HUB
- A3 CONTROL CABLE FROM TELLER UNIT.
- B COMBINATION LEVELING BOLT & ANCHOR (4x)
- C 4-1/2" CARRIER TUBE
- D BOLLARD
- E DUPLEX OUTLET FOR CONVENIENCE(OPTIONAL)
- F CONDUIT FROM OUTLET
- G CONTROL PANEL
- H VIDEO DISPLAY (OPTIONAL)
- J CAMERA (OPTIONAL)
- K AUDIO MICROPHONE
- L AUDIO SPEAKER
- M "CALL" BUTTON (2x)
- N "SEND" BUTTON (2x)
- P CUSTOMER UNIT MOUNTING BASE

**DO NOT SCALE**

# American Vault<sup>®</sup> Waco Texas

PRODUCT APPLICATION DRAWING  
**MODEL 745DD 4-1/2" DOWNSEND REMOTE SYSTEM**  
**(MODEL 745DCUS 4-1/2" CUSTOMER UNIT DETAILS)**  
**(6" to 9" RECOMMENDED TUBE SETBACK)**

SIZE	DWG NO	DATE	SHEET
<b>A</b>	20167	12.01.2023	5 OF 6

NOTES:

1. THE BRANCH CIRCUITS SUPPLYING THE 745 SERIES RTS MUST BE A DEDICATED CIRCUIT USING INDIVIDUAL HOT, NEUTRAL AND GROUND CONDUCTORS.
2. NEITHER THE CONDUIT NOR THE NEUTRAL SHOULD BE SHARED WITH OTHER CIRCUITS.
3. CONDUIT MUST NOT BE USED IN PLACE OF GROUND WIRE.
4. CUSTOMER UNIT LOAD IS 9.0 AMPS. TELLER UNIT LOAD IS 1.0 AMP. NO OTHER LOADS ARE TO BE CONNECTED TO THIS CIRCUIT.
5. ONE BREAKER IS TO SHUT DOWN ONE SYSTEM (CUSTOMER & TELLER UNIT) ONLY.
6. ALL WORK AND MATERIALS SHALL CONFORM TO NATIONAL, STATE & LOCAL ELECTRICAL CODES WHERE APPLICABLE.
7. ALL CONDUIT, POWER WIRES, JUNCTION BOXES, ETC. ARE TO BE PROVIDED BY OWNER'S ELECTRICAL CONTRACTOR.
8. THE OWNER'S ELECTRICAL CONTRACTOR IS RESPONSIBLE FOR THE GROUNDING OF ELECTRICAL EQUIPMENT.

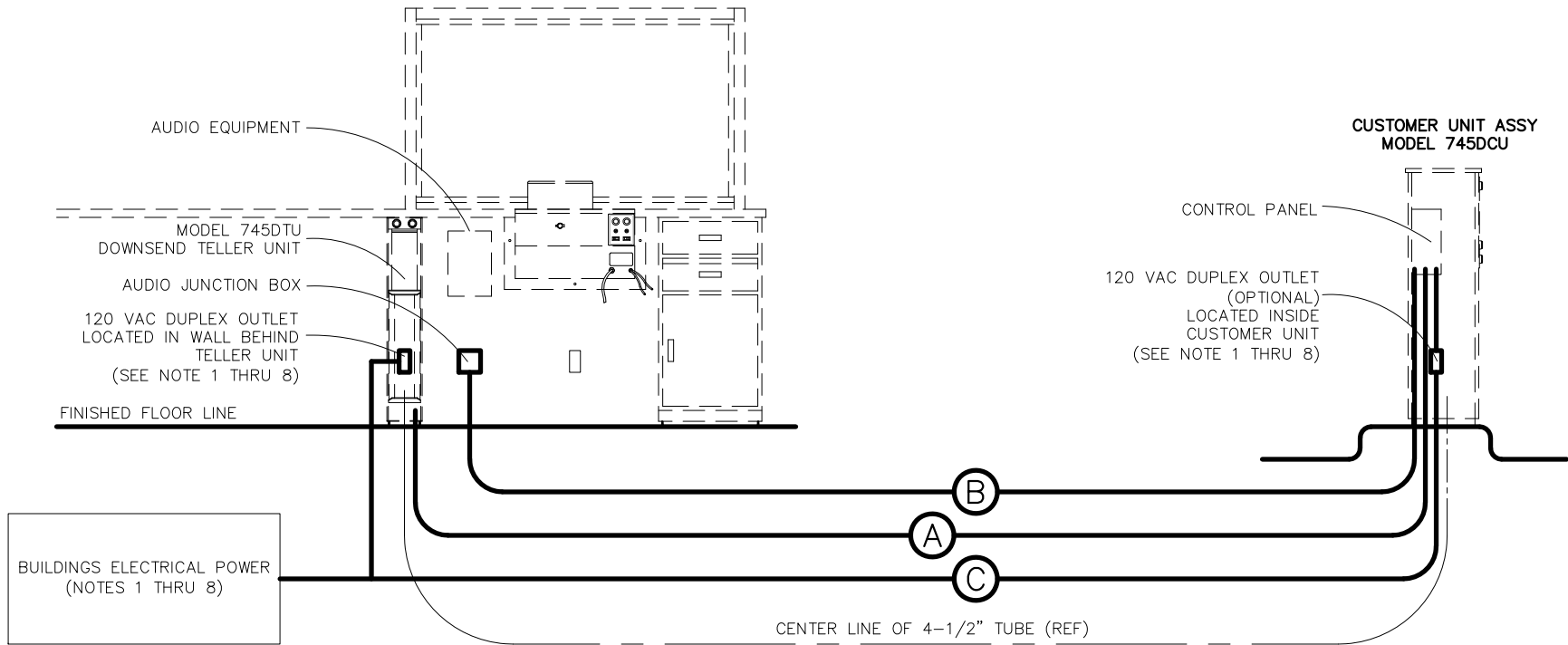

- (A)** 3/4" CONDUIT FOR CUSTOMER/TELLER INTERFACE CABLE 15 CONDUCTOR, 22GA. REF BELDEN #8456 OR EQUIV. AVC PART #2009-0003
- (B)** 3/4" CONDUIT FOR AUDIO AND VIDEO INTERFACE CABLE REFER TO AUDIO MANUFACTURERS SPECIFICATIONS FOR CABLE REQUIREMENTS
- (C)** 120 VAC, 60Hz, 1PH, 20 AMP DEDICATED BRANCH CIRCUIT (SEE NOTES 1 THRU 8)

DO NOT SCALE

**American Vault**® Waco Texas

PRODUCT APPLICATION DRAWING  
 MODEL 745DD 4-1/2" DOWNSEND REMOTE SYSTEM  
 (DOWNSEND TU to DOWNSEND CU)

SIZE	DWG NO	DATE	SHEET
<b>A</b>	20167	12.01.2023	6 OF 6

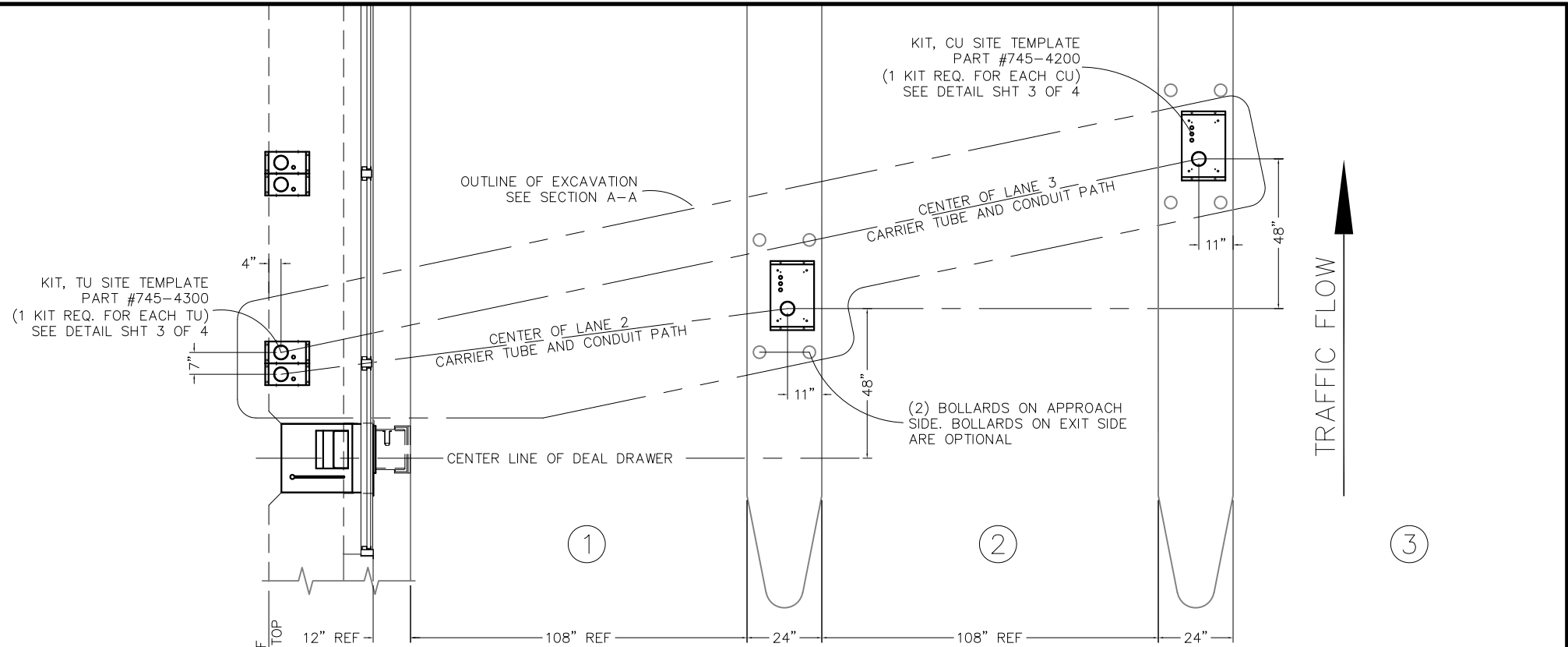

**HOLD TEMPLATES LEVEL  
WITH TOP OF CONCRETE.**

SITE TEMPLATES PROVIDED BY AVC TO BANK  
 EQUIPMENT CONTRACTOR (BEC) FOR INSTALLATION BY  
 OWNERS GENERAL CONTRACTOR (GC). BEC IS TO  
 COORDINATE INSTALLATION WITH GC.

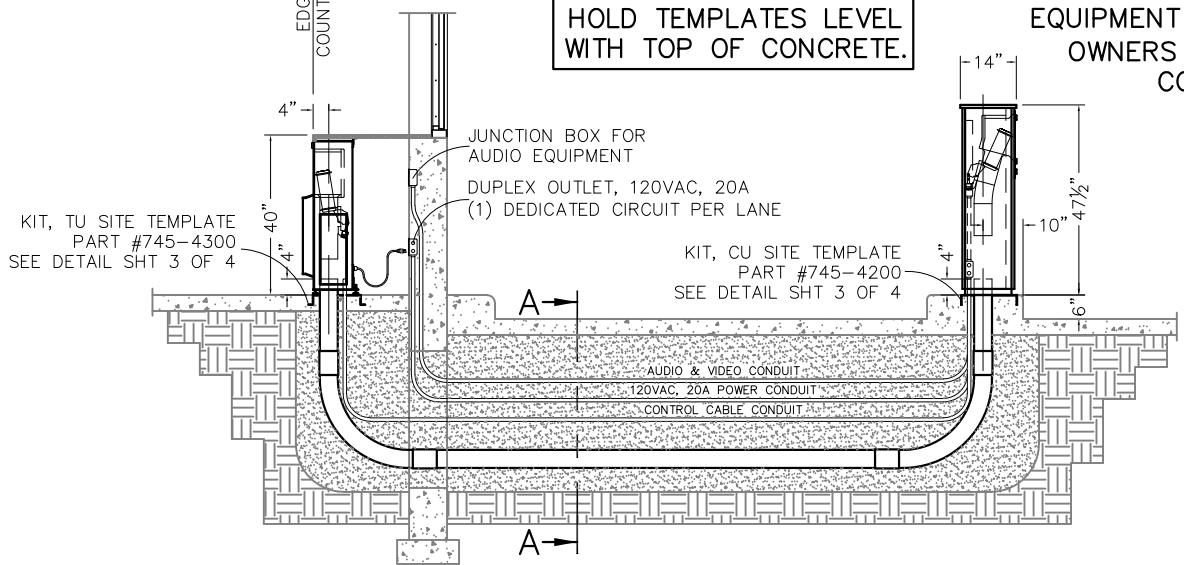

DO NOT SCALE

**American**  
**vault**<sup>®</sup> Waco Texas

PRODUCT APPLICATION DRAWING  
 MODEL 745DD 4-1/2" DOWSEND RTS  
 (DIRECT BURIAL TUBE DETAILS)

SIZE	DWG NO	DATE	SHEET
<b>A</b>	20167-01	12.01.2023	1 OF 4

FOR ADDITIONAL SPECIFICATIONS REFER TO DRAWING #20167.

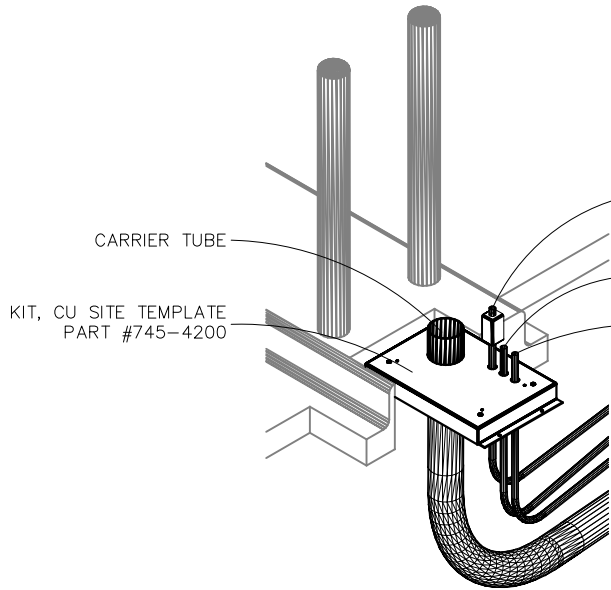

HOLD TEMPLATE LEVEL WITH TOP OF CONCRETE

DEDICATED CIRCUIT DUPLEX RECEPTACLE  
120VAC, 20A  
(ONE PER LANE)  
(TU AND CU ON SAME CIRCUIT)

120VAC, 20A DEDICATED CIRCUIT FROM TU  
(TU AND CU ON SAME CIRCUIT)  
(SHOWN WITH OPTIONAL DUPLEX CONVENIENCE OUTLET)

AUDIO AND OR VIDEO CONDUIT (3/4")

CONTROL CABLE CONDUIT (3/4")

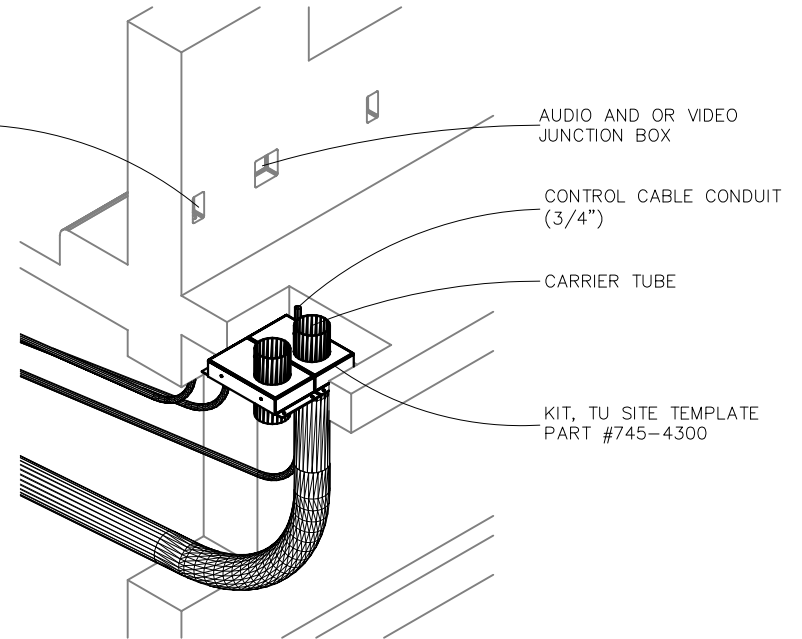

AUDIO AND OR VIDEO JUNCTION BOX

CONTROL CABLE CONDUIT (3/4")

CARRIER TUBE

KIT, TU SITE TEMPLATE PART #745-4300

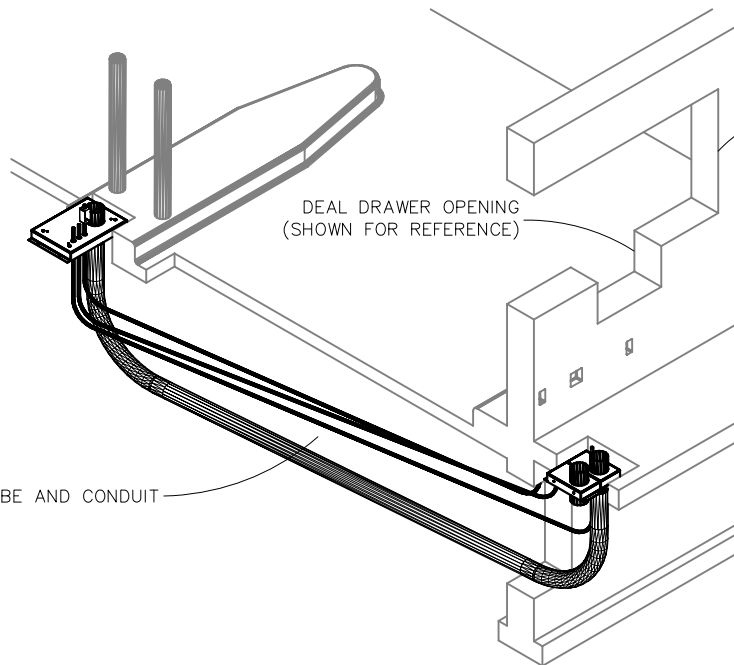

B/R WINDOW OPENING (SHOWN FOR REFERENCE)

DEAL DRAWER OPENING (SHOWN FOR REFERENCE)

BURIED CARRIER TUBE AND CONDUIT

FOR ADDITIONAL SPECIFICATIONS REFER TO DRAWING #20167

DO NOT SCALE

**American Vault**® Waco Texas

PRODUCT APPLICATION DRAWING  
MODEL 745DD 4-1/2" DOWNSEND RTS  
(DIRECT BURIAL TUBE DETAILS)

SIZE	DWG NO	DATE	SHEET
<b>A</b>	20167-01	12.01.2023	2 OF 4

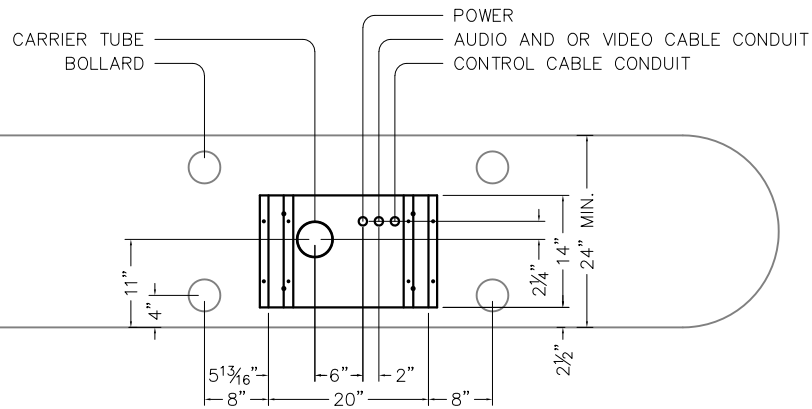

TRAFFIC FLOW

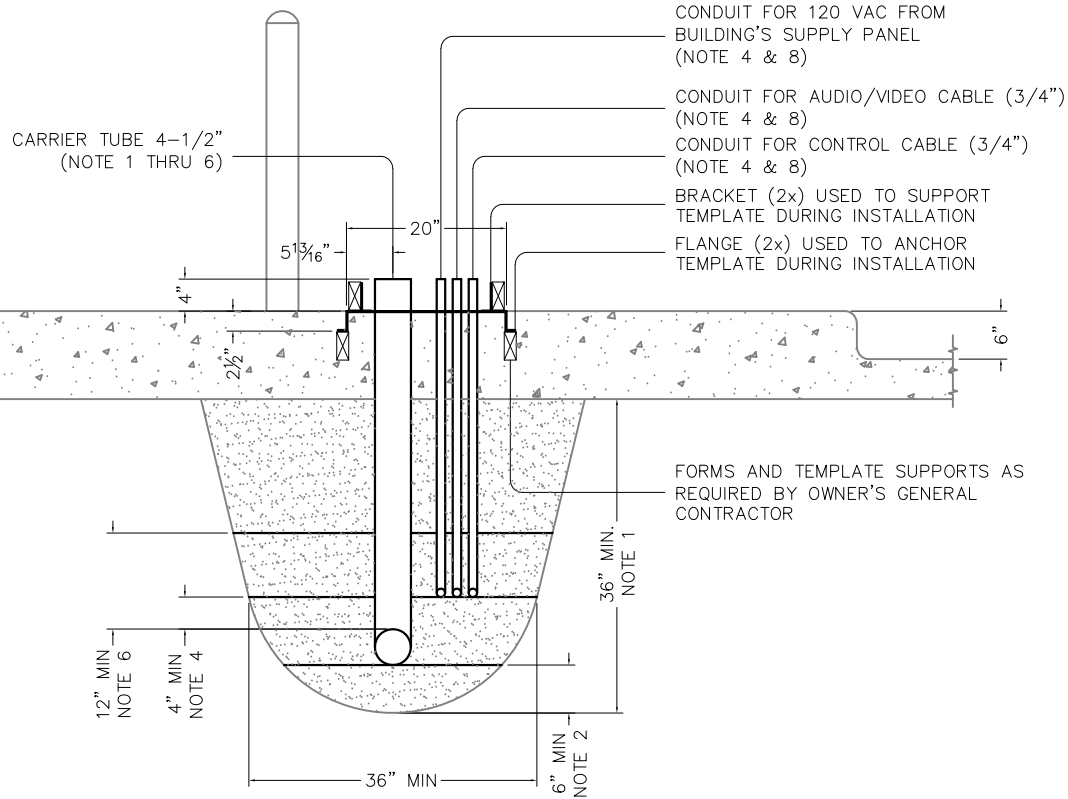

SECTION A-A

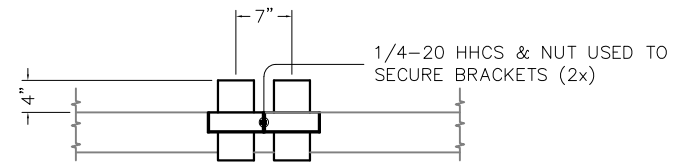
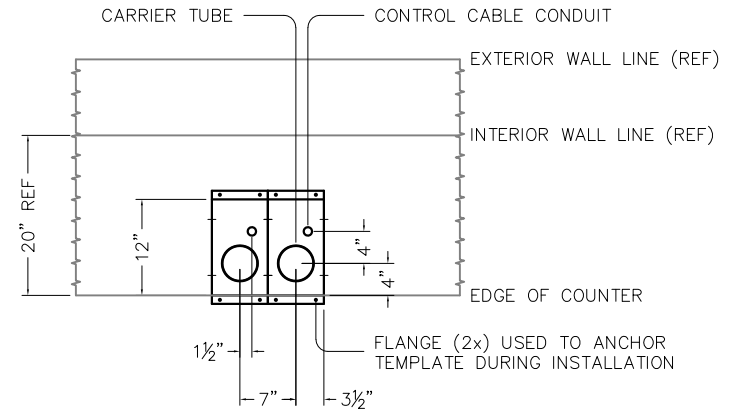

FOR ADDITIONAL SPECIFICATIONS REFER TO DRAWING #20167

DO NOT SCALE

**American**  
**Vault**® Waco Texas

PRODUCT APPLICATION DRAWING  
MODEL 745DD 4-1/2" DOWSEND RTS  
(DIRECT BURIAL TUBE DETAILS)

SIZE	DWG NO	DATE	SHEET
<b>A</b>	20167-01	12.01.2023	3 OF 4

NOTES:

1. OWNER'S GENERAL CONTRACTOR TO PROVIDE OSHA APPROVED TRENCH FROM UNDERSIDE OF TELLER TERMINAL TO CUSTOMER TERMINAL ISLANDS. ROUTING OF TRENCH TO BE DETERMINED BY THE OWNER'S GENERAL CONTRACTOR. MINIMUM DEPTH OF TRENCH IS 3'0". ACTUAL DEPTH IS DETERMINED BY ARCHITECT BASED ON JOB SITE CONDITIONS, SOIL, FROST LINE, CODE, ETC. TUBES ARE TO BE LOCATED BELOW FROST LINE.
2. BEFORE TUBES ARE INSTALLED OWNER'S GENERAL CONTRACTOR IS TO FILL EXCAVATION WITH 6" MINIMUM BASE OF CLEAN FILL SAND, WASHED AND COMPACTED WITH NO MORE THAN 10% OF 1/8" AGGREGATE PER ASTM-C-144-70.
3. TAPECOAT PROTECTED TUBING AND FITTINGS ARE TO BE USED BELOW GROUND. ALL JOINTS BELOW GROUND ARE TO BE PERMANENTLY JOINED BY BRAZING. ALL JOINTS ARE TO BE AIR-TIGHT AND SEALED USING TAPECOAT #20 AND HEAT SHRINKABLE PROTECTIVE SLEEVE TO ENSURE A WATER-TIGHT INSTALLATION. ALL TUBES ARE TO BE PRESSURE TESTED PRIOR TO BACKFILLING TRENCH.
4. BEFORE CONDUIT IS INSTALLED OWNER'S GENERAL CONTRACTOR IS TO COVER TUBES WITH 4" OF CLEAN FILL SAND, WASHED AND COMPACTED WITH NO MORE THAN 10% OF 1/8" AGGREGATE PER ASTM-C-144-70.
5. CONDUIT IS TO BE BURIED BY OWNER'S ELECTRICAL CONTRACTOR ABOVE TUBES AND SHALL NOT INTERFERE WITH THE TUBES.
6. OWNER'S GENERAL CONTRACTOR IS TO FILL SPACE ABOVE TUBES WITH 12" MINIMUM OF CLEAN FILL SAND, WASHED AND COMPACTED WITH NO MORE THAN 10% OF 1/8" AGGREGATE PER ASTM-C-144-70. TAKE CARE NOT TO DISTURB TUBES OR CONDUIT.
7. OWNER'S GENERAL CONTRACTOR TO BACKFILL AND COMPACT SOIL IN REMAINING SPACE OF TRENCH.
8. ALL CONDUIT AND POWER IS BY OWNER'S ELECTRICAL CONTRACTOR.
9. DETAILS SHOWN FOR ILLUSTRATION PURPOSES ONLY. LOCAL, STATE AND NATIONAL CODES DICTATE ACTUAL INSTALLATION.

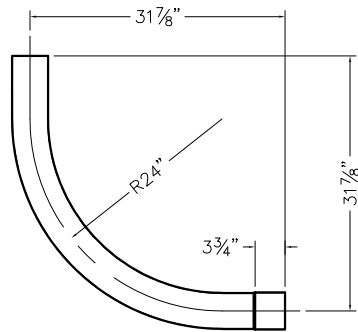

TAPECOAT STEEL BEND,  
ONE END EXPANDED,  
4-1/2x24R  
AVC PART #9034-0010  
(NOTE 3,4,5,6)



TAPECOAT STEEL TUBING  
ONE END EXPANDED,  
4-1/2x12'6"  
AVC PART #9034-0003  
(NOTE 3,4,5,6)

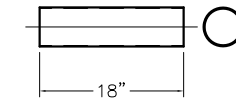

PROTECTION SLEEVE,  
4-1/2x18"  
AVC PART #9034-0020  
(NOTE 3,4,5,6)



STEEL SLEEVE,  
4-1/2x5  
AVC PART #9030-0150  
(NOTE 3,4,5,6)



TAPECOAT PRIMER,  
1 PINT CAN  
AVC PART #9034-0022  
(NOTE 3,4,5,6)

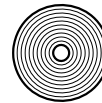

TAPE, TAPECOAT #20,  
75' ROLL  
AVC PART #9034-0021  
(NOTE 3,4,5,6)

DO NOT SCALE

**American**  
**vault**® Waco Texas

PRODUCT APPLICATION DRAWING  
MODEL 745DD 4-1/2" DOWSEND RTS  
(DIRECT BURIAL TUBE DETAILS)

SIZE	DWG NO	DATE	SHEET
<b>A</b>	20167-01	12.01.2023	4 OF 4

FOR ADDITIONAL SPECIFICATIONS REFER TO DRAWING #20167.

### 3 OPERATIONS

#### 3.1 Switches and Indicators

##### 3.1.1 Send Pushbutton (TU)

The send switch located on the teller control panel initiates a send cycle any time the system is not in the middle of a cycle, regardless of the position of either door or the carrier.

##### 3.1.2 Home Pushbutton (TU)

The home switch located on the teller control panel initiates a home cycle any time it is pushed. Even if the system is in the middle of a cycle, and regardless of the position of any doors or the carrier.

##### 3.1.3 Tset Pushbutton (TU-PCB)

The Tset switch located on the teller control P.C.B. initiates a travel time set sequence. This process is described further in section 3.2.3 of this manual.

##### 3.1.4 Sleep Rocker Switch (TU)

The sleep switch is located on the front panel of the Teller Unit. It is a lighted switch which is lit when the unit is in sleep mode. Sleep mode is described further in section 3.2.X of this manual

##### 3.1.5 Send lamp (TU)

The send lamp, located on the send switch indicates the system status for the send function. Off indicates that the system is not in the send mode, however the send switch will be recognized. On solid indicates that the system is in the send mode and expects the next operation to be send. On flashing indicates that the system is in a send cycle and the operator should wait.

##### 3.1.6 Home lamp (TU)

The home lamp, located on the home switch indicates the system status for the home function. Off indicates that the system is not in the home mode, however the home switch will be recognized. On solid indicates that the system is in the home mode and expects the next operation to be home. On flashing indicates that the system is in a home cycle and the operator should wait.

##### 3.1.7 Send Pushbutton (CU) (Two locations)

The customer send switch, located on the front of the customer unit, initiates a home cycle. This pushbutton is only active when the customer door is open during normal operation.

##### 3.1.8 Call Pushbutton (CU) (Two locations)

The call switch, located on the front of the customer unit, is part of the audio interface provided on the customer unit circuit board. Pressing this switch generates a call tone on the connected audio system. If the unit is in the 'Send with CU door Closed' mode, pressing the Call pushbutton also opens the customer door.

##### 3.1.9 Cycle Pushbutton (CU-PCB)

Located in upper left region of CU circuit board, This switch initiates a continuous cycle test. To exit this test, remove power from the CU board by removing the Connector at J1

##### 3.1.10 Door/Valve Pushbutton (CU-PCB)

Located in the upper left region of CU circuit board, This switch initiates a single cycle of the CU Door and the CU blower valve.

##### 3.1.11 Diag Pushbutton (CU-PCB)

Located in the upper left region of CU circuit board, This switch initiates a Teller Send function.

##### 3.1.12 Time Set Pushbutton (CU-PCB)

Located in the upper left quadrant of the CU circuit board, This switch initiates a Time Set function as described in section 3.2.3 of this manual.

##### 3.1.13 Time Set Pushbutton (TU-PCB)

Located in the upper left corner of TU circuit board, This switch initiates a Time Set function as described in section 3.2.3 of this manual.

### 3 Operations (continued)

#### 3.2 Functions

##### 3.2.1 Send

The send function is used to move the carrier from the teller position to the customer position. When this switch is pressed, the control checks the position of the customer door. If the door is not closed, a signal is generated to close it. Next, the position of the teller door is checked, if it is not fully closed, the door is closed. Next, the blower control valve is rotated into position. Then the send blower, located in the customer unit comes on pulling the carrier to the outside. The carrier then arrives at the customer unit. When the send blower time completes, the outside door opens, then the teller door closes, and the blower control valve moves to the home position. This completes the send cycle.

##### 3.2.2 Home

The home function is used to move the carrier from the customer position to the teller position. When this switch is pressed, the control checks the position of the customer door. If the door is not closed, a signal is generated to close it. Next, the position of the teller door is checked, if it is not fully closed, the door is closed. Next, the blower control valve is rotated into position. Then the home blower, located in the customer unit comes on pushing the carrier to the inside. The carrier then arrives at the teller unit. When the home blower time completes, the inside door opens, and the blower control valve moves to the send position. This completes the home cycle.

##### 3.2.3 Tset

This function is used to set the travel time of the carrier in both directions.

###### 3.2.3.1 Setting the send and home time:

1. Start with TU door open after initial power up.
2. Place carrier in TU carrier deposit chamber.
3. Press Tset switch on TU end or CU end.

The system will automatically send the carrier to the Customer end then recall it to the Teller end. When the carrier returns to the Teller end and the TU door opens, The time set procedure is complete and the system is ready for use.

##### 3.2.4 Customer Send

This function is used by the customer to move the carrier from the customer terminal to the teller terminal. This switch is only active after the successful completion of a send function. Once the customer send switch is recognized by the control, the sequence is identical to the home cycle.

##### 3.2.5 Recall before delivery

Recall is used to return a carrier to the teller before the customer has the chance to retrieve it. It is useful if the teller sends the wrong carrier to a lane. Recall is activated by holding the home switch during a send cycle. After the switch is held for about 1 second, the home lamp will begin flashing. This indicates that the recall is pending. When the carrier lands outside it will immediately return before the door opens. Once the customer door begins to open, the recall function will not be accepted.

##### 3.2.6 Sleep Mode.

Sleep mode is used to prevent air inside the bank from circulating through the tube and causing condensation. To enter sleep mode, Simply activate the sleep switch at any time. The carrier will be returned to the TU and both doors will close. The led in the sleep switch will be lit to indicate the TU is in sleep mode. Simply move the switch to the off position to return the system to service.

##### 3.2.7 Send with CU Door Closed.

This mode is useful if the operator wants to keep the customer door closed for weather conditions or to prevent vandalism. To enter this mode, press and hold the Send pushbutton on the TU until the blowers turn on. To exit this mode, the Teller can press the send pushbutton or the customer can press the call pushbutton.





7500 Mars Drive  
Waco, TX 76712  
(254) 776-0100 P  
(254) 776-0700 F  
[www.AmericanVault.us](http://www.AmericanVault.us)

## **4 MAINTENANCE**

### **4.1 Cleaning**

The customer and teller units should be cleaned with a mild cleaner and a soft cloth. Any debris should be removed from the carrier deposit chambers as they could prevent proper operation of the system. Use of harsh solvents or acids could damage the finish of the system.

### **4.2 Preventative maintenance**

There are no user serviceable parts in the customer or teller units and all service should be performed by authorized service personnel. The system should be serviced yearly to check the condition of drive components, and to remove any debris from the inside of the customer and teller units. The serviceman should check the motors, drive belts and rollers for signs of excessive wear, and replace if necessary.

## 5 SERVICE

### 5.1 Fault Analysis

There are indicators on the teller and customer units which help in troubleshooting the Model 745 Downsend RTS. They are outlined below.

#### 5.1.1 Teller Unit

##### 1. Send Light

This lighted switch is lit upon proper initialization of the teller unit. It indicates that the system is ready for a send operation. This switch will flash during a send cycle, signaling that the operation is currently in process.

##### 2. Home Light

This lighted switch is lit after a Send operation is complete. It indicates that a home operation is the next intended operation. This switch will flash during a home cycle, signaling that the operation is currently in process. It will also be lit during a send cycle signaling that a recall before delivery cycle can be initiated.

#### 5.1.2 Customer unit

##### 1. Send and Call Lights

Send and Call lights are lit directly from the +12 volt supply of the Customer PCB. If these lights are not on then +12VDC is not present on the outside board.

### 5.2 Pre-requisite vs. Stand-alone functions

The functions of the Model 700 RTS can be divided into two groups. Stand alone functions and pre-requisite functions.

5.2.1 Stand-alone functions are those that don't require certain conditions for operation. These include the following:

1. Teller Send
2. Teller Home
3. Teller and Customer door operations
4. Diverter valve operation
5. Time Set

Time Set can be initiated from any status condition provided that the carrier is in the system. If the carrier is in any location other than the chamber of the Teller Unit then the Time Set routine will need to be run twice, otherwise the send time will be too short. This is convenient if you are inserting the carrier from outside at the CU.

5.2.2 Pre-requisite operations are those that require that certain conditions exist in order to complete properly. These include:

##### 1. Home Blower

Teller and Customer door closed limit switches must remain activated in order for the home blower cycle to complete. If either door opens, the blower cycle will end immediately. If either door fails to close, the blower cycle will be skipped.

##### 2. Send Blower

Customer door closed limit switch must remain activated in order for the send blower cycle to complete. If customer door opens, the blower cycle will end immediately. If customer door fails to close, the blower cycle will be skipped.

##### 3. Customer Send

Customer Send is only active after the completion of a Teller Send cycle.

## 5 SERVICE (continued)

### 5.3 Field Wiring

#### 5.3.1 Control Wiring

- +V

+12Vdc supplies power for TU Sleep pushbutton lamp.

- GND Control Common
- OPEN Teller Door Open

A positive voltage on this wire will cause the teller door to open. 0 VDC inactive, 1.0 VDC active.

- CLOSE Teller Door Close Limit

A positive voltage on this wire will cause the customer door to close. 0 VDC inactive, 1.0 VDC active.

- O LIMIT Teller Door Open Limit

The Customer PCB Controller holds this wire at 10 VDC. The Teller Door open limit switch pulls this wire to GND when the door is fully open.

If this circuit fails OPEN, the door will chatter for a few seconds when the limit is reached but the system will otherwise function. If this circuit fails closed, the door will not open because the Customer PCB Controller thinks it already is fully open.

- C LIMIT Teller Door Close Limit

The Customer PCB Controller holds this wire at 10 VDC. The Teller Door close limit switch pulls this wire to GND when the door is fully closed.

If this circuit fails OPEN, the door will chatter for a few seconds when the limit is reached and the blower motor will not turn on. If this circuit fails closed, the door will not close because the teller board thinks it already is fully open.

- UNLATCH

A positive voltage on this wire will cause the Teller Carrier Latch to retract. 0 VDC inactive, 1.0 VDC active

- LAT LIMIT

The Customer PCB Controller holds this wire at 10 VDC. The Teller Latch Retract limit switch pulls this wire to GND when the latch is retracted.

This switch is used to indicate that the carrier has arrived at the Teller Station.

- TSET SW

The Customer PCB Controller holds this wire at 10 VDC. The tset pushbutton on the teller pcb pulls this signal to 0 VDC to initiate a time set operation.

- SLEEP SW

This rocker switch initiates the sleep mode.

- SEND

The Customer PCB Controller holds this wire at 10 VDC. The Teller Send switch pulls this wire to GND when it is pressed.

- HOME

The Customer PCB Controller holds this wire at 10 VDC. The Teller Send switch pulls this wire to GND when it is pressed.

- SEND LAMP

The Customer PCB Controller controls this wire to turn the lamp in the Teller send Pushbutton on and off.

- HOME LAMP

## 5 SERVICE (continued)

### 5.3 Field Wiring (continued)

#### 5.3.1 Audio Wiring

- SPKR+
- SPKR-
- CALL
- MUTE
- COMMON
- SHLD
- MIC-
- MIC+

### 5.4 Troubleshooting Guide

<b>Symptom: Unit Will Not Power-Up</b>	
<b>Checks</b>	<b>Corrective Action</b>
110 VAC Power	Check 110 VAC Power to teller and customer units.
12 VDC Power	Check for Send and Call pushbutton lights on the customer unit. These work directly off of 12 VDC and should always be on.
Field wiring	Disconnect field wiring from the Customer end. Power up Customer end. If the door opens and the send light lights up then there is a crossed wire or a short in the field wiring or the teller board is shorting out the 12 volt supply.
Fuses	Fuses on customer board are self resetting provided that the over current condition has been cleared.
Wiring	Check wiring harness on teller board and between customer and teller units.
Teller Board	Check for damaged connectors, traces or components on the customer board

## 5 SERVICE (continued)

### 5.4 Troubleshooting Guide (continued)

<b>Symptom: Blower Control Valve Does Not Operate</b>	
<b>Checks</b>	<b>Corrective Action</b>
Check valve for free movement up & down	Remove the motor with its mounting plate from the blower assembly. Make sure the valve spool can be moved up & down freely. If the spool is not free, remove it and check for debris or burrs.
Actuator Arm	The Actuator Arm on the valve assembly should move freely. Make Shoulder Screws are not binding in slots
Power	Ensure that 120 VAC power is present at the Customer board. this may be checked with a DVM at TB1
Relays	You should not attempt to measure the relays directly because of the

	<p>possibility of damage however you can measure the voltage on the field wiring. This is the terminal marked GVO gate valve open, and GVC gate valve close.</p> <p>This voltage should be 0 volts normally and about 1.1 volts when operating. If this voltage exceeds 4.5 volts when operating, the relay for the related function is defective. In order to check the output side of the relay you will have to complete the above step to prove the input is working then substitute a known good board. If the motor still does not work then the board should be replaced.</p>
Gear motor	See gear motor section

<b>Symptom: Blowers Do Not Come On</b>	
<b>Checks</b>	<b>Corrective Action</b>
Blower Signal	The Solid state relay has a green indicator light that will light up when the blower signal is present. You may also measure the activation voltage on the small terminals of the Solid state relay, A1 (+) and A2(-). The voltage should be approximately 3 Volts DC
Power	Verify that blowers are connected to 110 VAC power.
Wiring	Check wiring for proper connection and continuity.
Blower Motor	Measure the AC voltage across the load side of the Solid state relay, L1 and T1. when the blower motors are not running. If this voltage is less than the 120 VAC supply voltage, the motor brushes are likely worn out. You may also check the blower motor by bypassing solid state relay and powering the motor directly. You MUST disconnect power while rewiring blower. Failure to do so could result in injury or death.
Door positions	In order for the blowers to be turned on, the doors must be closed. If the controller doesn't recognize that the doors are closed, the blowers will not turn on. This could be caused from defective door motors, defective door limit switches, wiring problems or a defective microcontroller.
Solid State Relay	The solid state relay can be checked by the process of elimination. If you verify that the blower signal is present and verify the operation of the blower motor, it can be assumed that the relay is defective.



**5 SERVICE (continued)**

5.4 Troubleshooting Guide (continued)

<b>Symptom: Teller Door Will Not Operate</b>	
<b>Checks</b>	<b>Corrective Action</b>
Check door for freedom of movement	Remove the drive plate from the unit. Make sure the door can move up and down freely. The door should slide down by its own weight.
Door seal	Ensure that the door is not binding in the door seal.
Power	Ensure that 120 VAC power is present at the Customer board. this may be checked with a DVM at TB1
Relays	You should not attempt to measure the relays directly because of the possibility of damage however you can measure the voltage on the field wiring. This is the terminal marked OPEN teller terminal open, and CLOSE teller terminal close. This voltage should be 0 volts normally and about 1.1 volts when operating. If this voltage exceeds 4.5 volts when operating, the relay for the related function is defective. In order to check the output side of the relay you will have to complete the above step to prove the input is working then substitute a known good motor. If the motor works then the Solid State relay is defective.
Limit Switches	Make sure that the limit switch connections are good and that the switch has continuity. Check the limit switch 'away' from the door drive block. If this switch is defective the door won't move to it.
Wiring	Check all wiring and connections in the limit switch and motor harness. Check closely for damaged contacts in the connectors which may appear OK but may not be making contact.
Gear motor	The motor lead resistance should be 1,660 Ohms nominally from black to blue and red to blue. There should be no continuity from red to case, red to black or black to case. If motor is running but the output shaft is not turning, the gearbox may be defective.

## 5 SERVICE (continued)

### 5.4 Troubleshooting Guide (continued)

<b>Symptom: Customer Door Will Not Operate</b>	
<b>Checks</b>	<b>Corrective Action</b>
Check door for freedom of movement	Remove the drive plate from the unit. Make sure the door can move up and down freely. The door should slide down by its own weight.
Door seal	Ensure that the door is not binding in the door seal.
Power	Ensure that 120 VAC power is present at the Customer board. this may be checked with a DVM at TB1
Over-travel Switches	The over-travel switches are secondary to the door limit switches. They are connected normally closed. If the switch in the direction of travel is actuated the motor circuit is opened and the motor will not run. Ensure that this switch is not actuated during normal operation. The actuator arm should not actuate the over-travel switch at or before the end limit switch is actuated.
Limit Switches	Make sure that the limit switch connections are good and that the switch has continuity. Check the limit switch 'away' from the door drive block. If this switch is defective the door won't move to it.
Wiring	Check all wiring and connections in the limit switch and motor harness. Check closely for damaged contacts in the connectors which may appear OK but may not be making contact.
Gear motor	The motor lead resistance should be 55 Ohms nominally from black to yellow and black to red. Red to Yellow should be 110 ohms. There should be no continuity from red, yellow or black to case. If motor is running but the output shaft is not turning, the gearbox may be defective.

Note: The Customer door can be moved manually. The armature shaft protrudes from the motor stack approximately 1/8". It is a 3/32 diameter shaft. If the armature shaft is lightly pressed in the brake mechanism will release and allow the actuator arm to be moved manually. The armature shaft must be held about half way in. if it is pressed too far it will bind up and prevent movement of the actuator arm. Only apply light pressure to the actuator arm to prevent damage to it.