

---

**700 Series Remote Transaction System (RTS)  
Installation and Operation Manual  
January 01, 2024**



Model 700-00 Upsend

Model 700-01 Upsend



7500 Mars Drive  
Waco, TX 76712  
(254) 776-0100 P  
(254) 776-0700 F  
[www.AmericanVault.us](http://www.AmericanVault.us)

## **TABLE OF CONTENTS**

### **DISCLAIMER**

### **WARNINGS**

## **1 INTRODUCTION**

- 1.1 Product Overview
- 1.2 General Specifications
- 1.3 System Components & Specifications  
(Drawing #20089)

## **2 INSTALLATION**

- 2.1 Unpacking Instructions
- 2.2 Site Requirements
- 2.3 Installation Procedure
- 2.4 System Interconnect Diagram  
(Drawing #700-1001C)

## **3 OPERATION**

- 3.1 Switches and Indicators
- 3.2 Functions

## **4 MAINTENANCE**

- 4.1 Cleaning
- 4.2 Preventative Maintenance

## **5 SERVICE**

- 5.1 Fault Analysis
- 5.2 Pre-requisite vs. Stand-alone functions
- 5.3 Field Wiring
- 5.4 Troubleshooting Guide



## DISCLAIMER

The material in this manual is for information purposes only. The contents and the product described are subject to change without notice. The manufacturer makes no presentations or warranties with respect to this manual. This product was designed for certain applications only. It may not be modified and/or used for any applications other than that which it was designed. The design specifications of the product described herein is subject to change without notice. The manufacturer reserves the right to make such changes without incurring any obligation to make them in units previously sold. Differences between the unit you received and the views contained herein are the result of design improvement and/or the addition of options as specified.

## WARNINGS

**Caution:** If not properly installed, operated and maintained, the use of this equipment presents the possibility of personal injury or property damage. Before use, all persons who will install, operate or maintain this product should read this manual thoroughly. For safe, dependable performance, follow all instructions and recommendations contained herein.

**Caution:** To prevent fire or shock, do not expose this product to rain or any type of moisture.

**Caution:** Keep hands clear of moving parts.

**Caution:** Always unplug unit from power source prior to cleaning or servicing unit.

## 1 INTRODUCTION

### 1.1 Product overview

This pneumatic tube system is a durable, field proven unit. It has been designed to provide easy access by both customer and teller, and reliable operation under harsh conditions.

This pneumatic tube system is for overhead tube applications using the proven push-pull method. Blowers are located in the customer unit and insulated for quiet operation. This system features teller units which do not block the tellers view.

### 1.2 General Specifications

Power Requirements:	120 VAC 5-/60 Hz.	15 Amp Circuit
Power Consumption:	Kiosk:	1 Amp
	Blowers:	9 Amps ea.
Maximum package weight:	No more than 4 roll of coins, otherwise limited only by space in carrier.	
Maximum carrier velocity:	40 feet per second	

### 1.3 System Components & Specifications

(Refer to following pages, drawing #20089)

**NOTES:**

1. WHEN ORDERING SPECIFY SET-UP FOR PVC OR STL AND COLOR. SYSTEM MODEL 700-00 SET-UP FOR PVC TUBING OR SYSTEM MODEL 700-01 SET-UP FOR STEEL TUBING.
2. ORDER ADDITIONAL TUBING, BENDS, FITTINGS, ETC. AS REQUIRED.
3. AVAILABLE IN AVC NEUTRAL TAN OR BLACK w/STAINLESS.

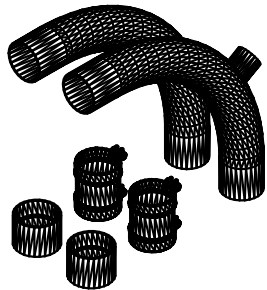

ADDITIONAL COMPONENTS PROVIDED  
WHEN ORDERING  
SYSTEM MODEL 700-01  
SET-UP FOR STEEL TUBING

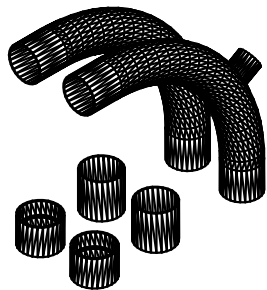

ADDITIONAL COMPONENTS PROVIDED  
WHEN ORDERING  
SYSTEM MODEL 700-00  
SET-UP FOR PVC TUBING

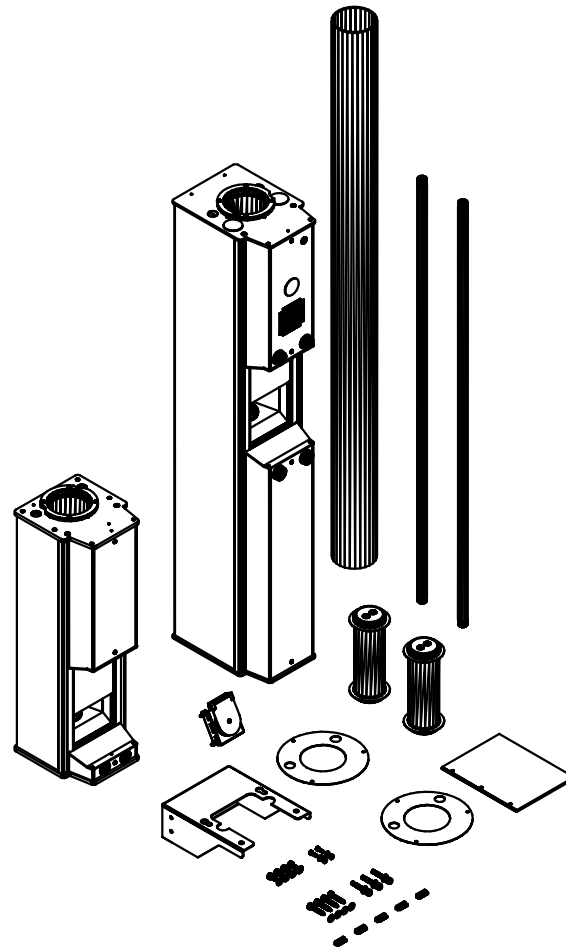

BASIC SYSTEM COMPONENTS

1	9030-0008	STL BEND w/REL 4-1/2 90D	1,2
1	9030-0004	STL BEND. 4-1/2 20R 90D	1,2
2	9030-0009	COUPLING 4-1/2" x 6	1,2
2	701-9708	ADAPTER, STL TO CLR	1,2
QTY	PART NO.	DESCRIPTION	NOTE
ADDITIONAL COMPONENTS PROVIDED w/STL SYSTEM (MODEL 700-01)			

1	9031-0003	PVC BEND, 4-1/2 20R 90D w/RELIEF	1,2
1	9031-0002	PVC BEND, 4-1/2 20R 90D	1,2
2	9031-0004	PVC COUPLING, 4-1/2"	1,2
2	701-9715	ADAPTER, PVC TO CLEAR	1,2
QTY	PART NO.	DESCRIPTION	NOTE
ADDITIONAL COMPONENTS PROVIDED w/PVC SYSTEM (MODEL 700-00)			

1	9030-0001	TUBING, CLEAR 10' LG	1,2
8	8180-0338	WASHER, FLAT 3/8"	1,2
2	8180-0325	WASHER, 1/4 FLAT	1,2
2	8150-0325	NUT, HEX 1/4-20	1,2
3	8097-0001	ANCHOR, 3/8x2-3/4 WEDGE	1,2
4	8096-3764	SCREW, HEX LAG 3/8x2-3/4	1,2
2	8095-3724	HHCS, 1/4-20x3/4	1,2
4	8095-3024	HHCS, 3/8-16x3/4	1,2
5	7428-0008	PLUG, 8 POS TERM BLOCK	1,2
2	4001-77AF	CARRIER, SIDE OPEN 4.29	1,2
2	702-9752	TRANSITION COVER PLATE	1,2
1	702-1000	FINAL ASSY, MODEL702 CT (COLOR SPECIFIC)	1,2,3
1	701-9707	BRACKET, WALL MOUNT (COLOR SPECIFIC)	1,2,3
1	701-1000	FINAL ASSY, 701 TT (COLOR SPECIFIC)	1,2,3
2	700-9911	CONDUIT (COLOR SPECIFIC)	1,2,3
1	700-3200	AIR BYPASS VALVE ASSY	1,2
1	700-1002	MANUAL, 700 RTS OP/INSTALL	1,2
QTY	PART NO.	DESCRIPTION	NOTE

SYSTEM COMPONENTS

DO NOT SCALE

**American Vault**<sup>®</sup> Waco Texas

PRODUCT APPLICATION DRAWING  
700 SERIES RTS 4-1/2" UPSEND  
SYSTEM COMPONENTS  
MODEL 700-00 PVC MODEL 700-01 STEEL



SIZE	DWG NO	DATE	SHEET
A	20089	12.01.2023	1 OF 5

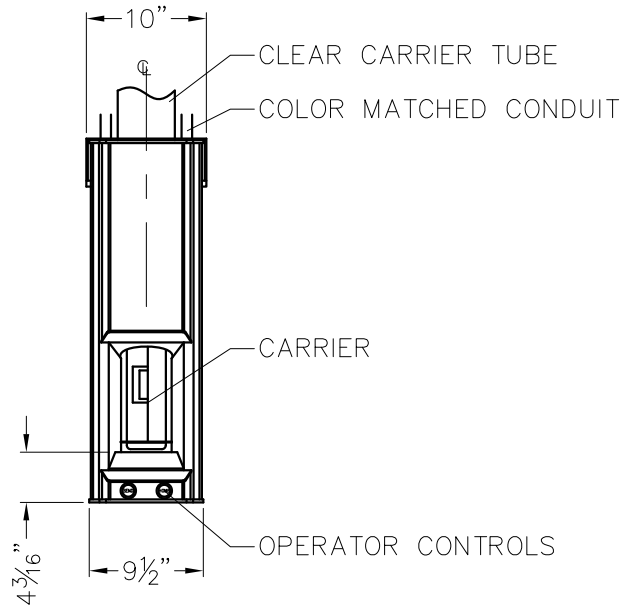
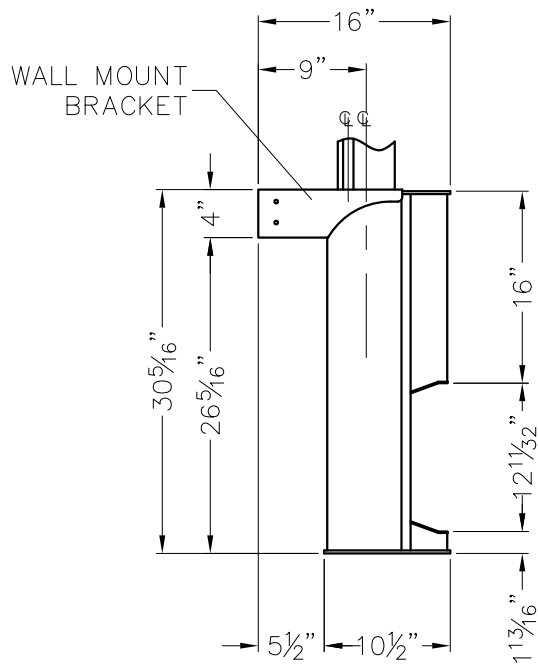
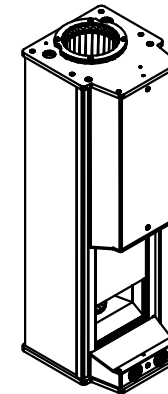
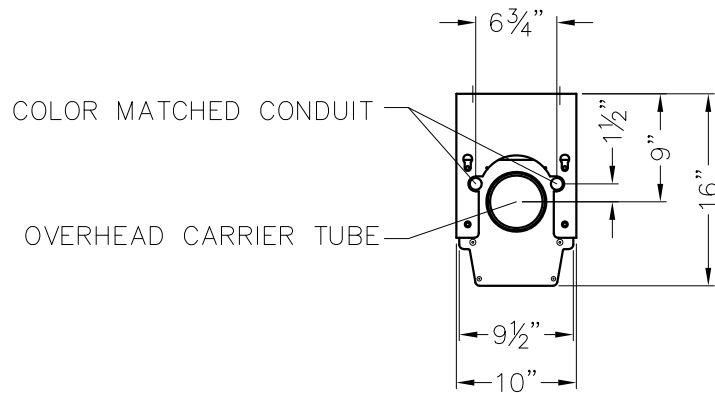

DO NOT SCALE

**American**  
**Vault**® Waco Texas

PRODUCT APPLICATION DRAWING  
 700 SERIES RTS 4-1/2" UPSEND  
 MODEL 701 TELLER TERMINAL DETAIL



SIZE	DWG NO	DATE	SHEET
A	20089	12.01.2023	2 OF 5

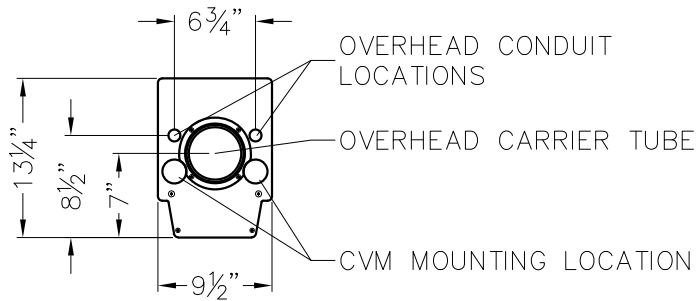

TOP PLATE DETAIL

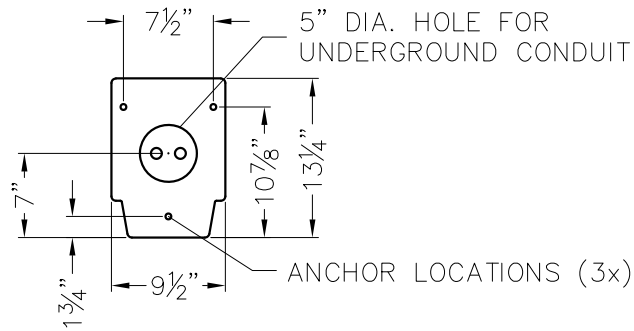

BASE PLATE DETAIL

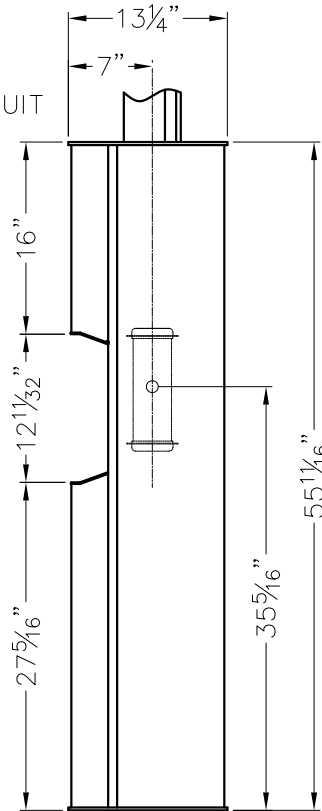
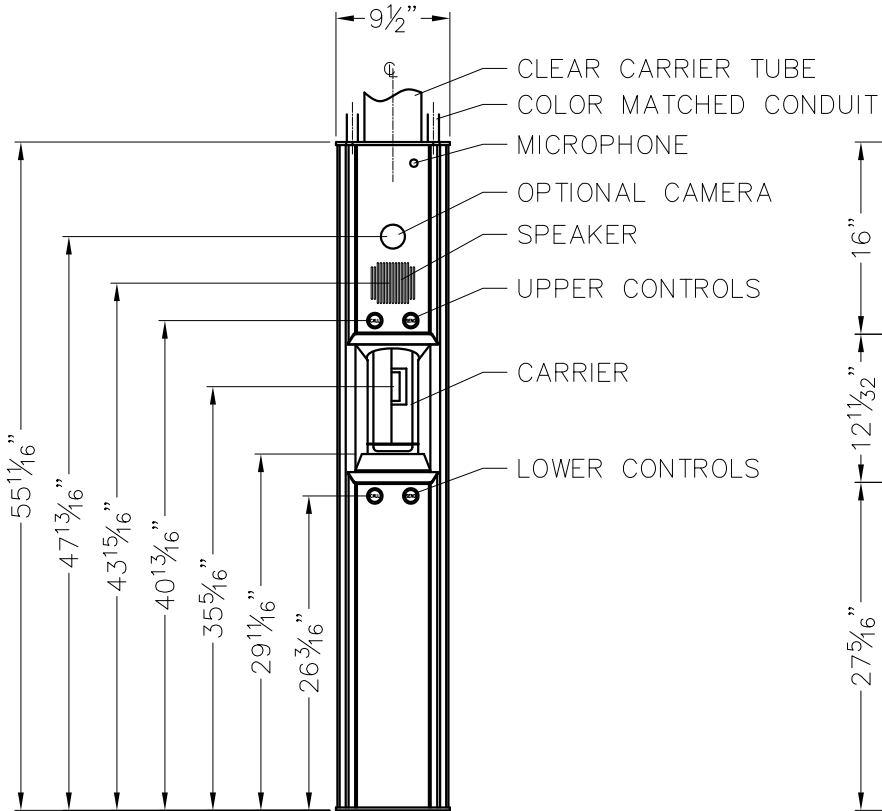
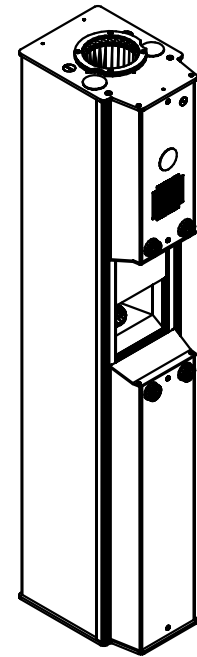

DO NOT SCALE

**American**  
**vault**® Waco Texas

PRODUCT APPLICATION DRAWING  
700 SERIES RTS 4-1/2" UPSEND  
MODEL 702 CUSTOMER TERMINAL DETAIL

SIZE	DWG NO	DATE	SHEET
<b>A</b>	20089	12.01.2023	3 OF 5

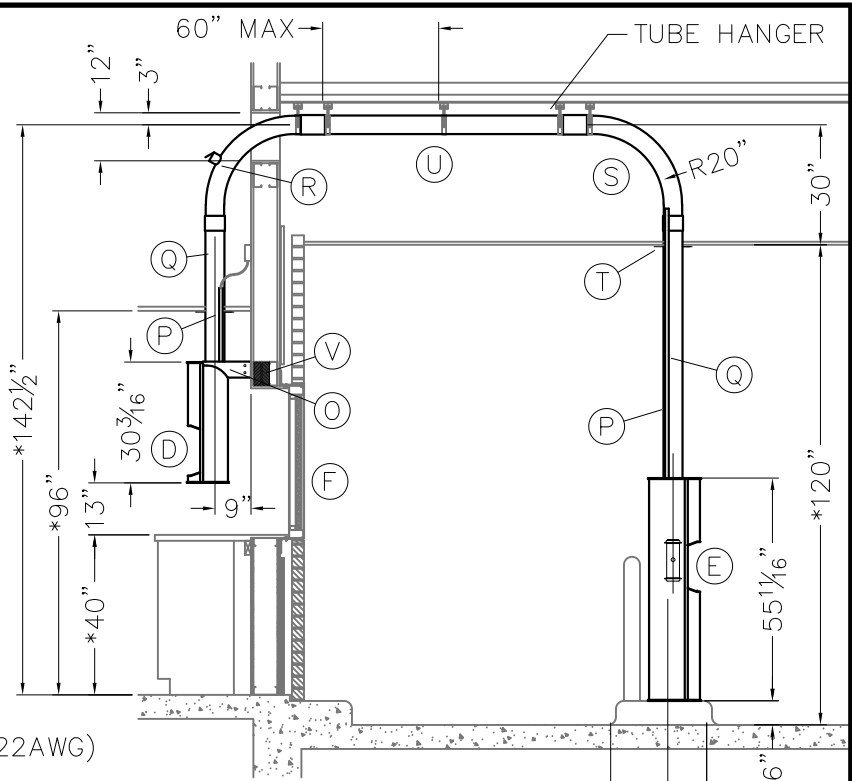
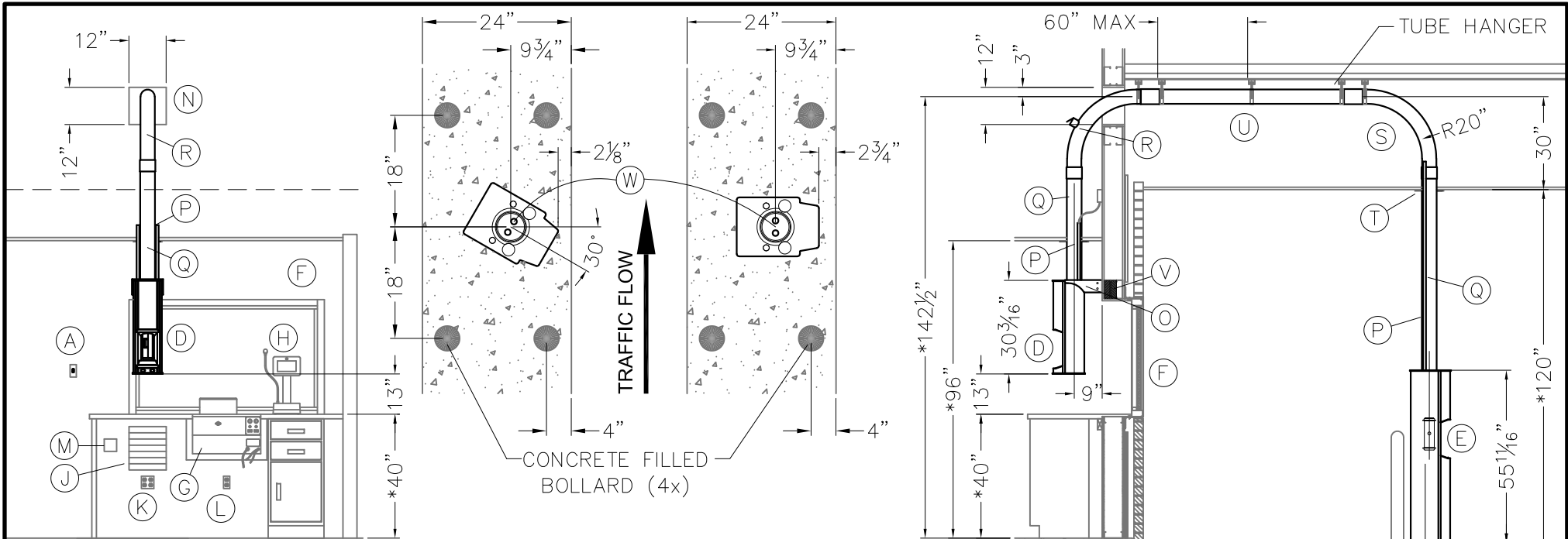

\*DIMENSIONS MARKED WITH AN ASTERISK MAY VARY WITH BUILDING/CANOPY CONSTRUCTION. REFER TO ADDITIONAL NOTES ON SHEET 5 OF 5.

LEGEND

- A T/T TO C/T INTERFACE CABLE (15C 22AWG)
- B AUDIO/VIDEO INTERFACE CABLE
- C 120 VAC, 20 A SWITCHED CIRCUIT
- D 700 RTS TELLER TERMINAL
- E 700 RTS CUSTOMER TERMINAL
- F B/R WINDOW
- G MODEL 1000A DEAL DRAWER
- H AUDIO CONSOLE+VIDEO DISPLAY
- I NOT USED
- J AUDIO MATRIX
- K QUAD OUTLET, 120 VAC
- L DUPLEX OUTLET, 120 VAC
- M 4x4 BOX WITH COVER PLATE FOR AUDIO & VIDEO CABLE
- N WALL OPENING FOR CARRIER TUBES
- O T/T WALL MOUNT BRACKET
- P COLOR MATCHED CONDUIT (3/4" EMT)
- Q CLEAR CARRIER TUBE
- R CARRIER BEND w/AIR RELIEF
- S CARRIER BEND
- T CEILING TRANSITION PLATE
- U CARRIER TUBE
- V BLOCKING FOR TELLER TERMINAL
- W UNDERGROUND CONDUIT LOCATION



DO NOT SCALE

**American Vault**® Waco Texas

PRODUCT APPLICATION DRAWING  
700 SERIES RTS 4-1/2" UPSEND  
INSTALLED VIEW

SIZE	DWG NO	DATE	SHEET
<b>A</b>	20089	12.01.2023	4 OF 5

- Ⓐ CUSTOMER/TELLER INTERFACE CABLE  
15 CONDUCTOR, 22GA.  
AVC PART #2009-0003
- Ⓑ AUDIO INTERFACE CABLE  
(REFER TO AUDIO SPEC'S  
FOR CABLE TYPE)
- Ⓒ 120 VAC, 60Hz, 1PH, 20 AMP  
DEDICATED SWITCHED BRANCH CIRCUIT  
(NOTE 1)

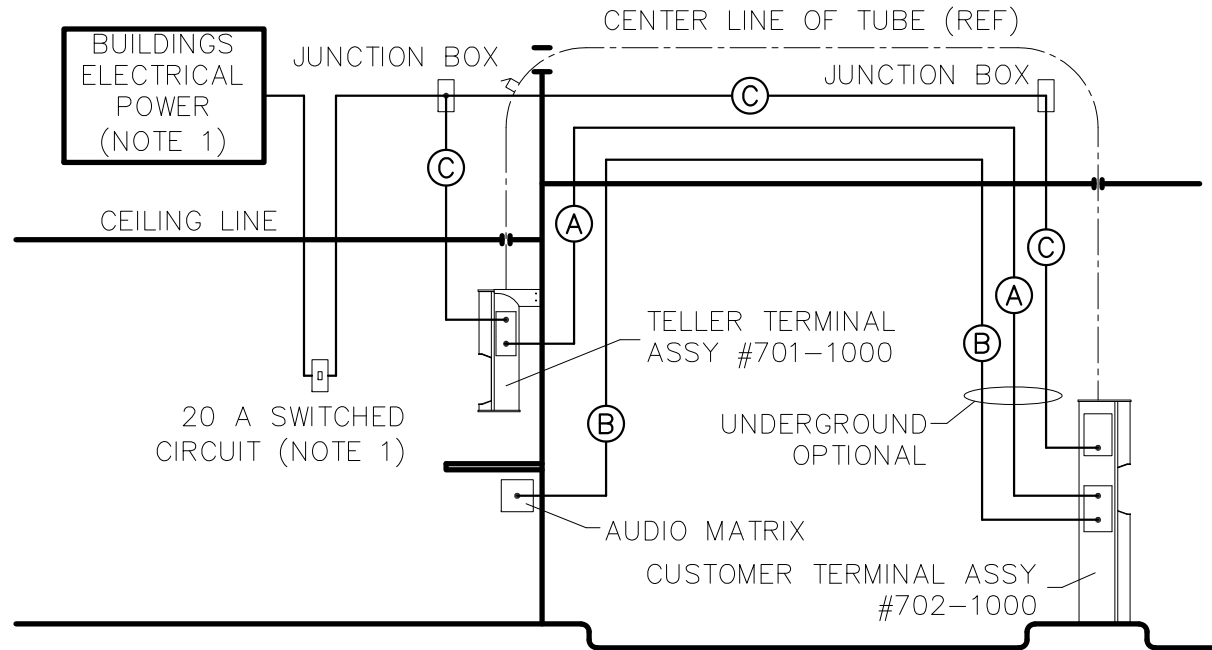

NOTES:

1. THE BRANCH CIRCUITS SUPPLYING THE 700 SERIES RTS MUST BE A DEDICATED CIRCUIT USING INDIVIDUAL HOT, NEUTRAL AND GROUND CONDUCTORS.
2. NEITHER THE CONDUIT NOR THE NEUTRAL SHOULD BE SHARED WITH OTHER CIRCUITS.
3. CONDUIT MUST NOT BE USED IN PLACE OF GROUND WIRE.
4. CUSTOMER UNIT LOAD IS 9.0 AMPS. TELLER UNIT LOAD IS 1.0 AMP. NO OTHER LOADS ARE TO BE CONNECTED TO THIS CIRCUIT.
5. ONE BREAKER IS TO SHUT DOWN ONE SYSTEM (CUSTOMER & TELLER UNIT) ONLY.
6. CANOPY AND SOFFIT DIMENSIONS SHOWN ARE REQUIRED TO FULLY ENCLOSE BEND AND TUBE TRANSITION. VARYING FROM THESE DIMENSIONS IS ACCEPTABLE, HOWEVER THE TRANSITION WILL BE EXPOSED.
7. THE RECOMMENDED MINIMUM ISLAND WIDTH IS 24". AN ISLAND WIDTH LESS THAN THIS CAN BE USED WITH PROPER PROTECTIVE BOLLARDS AND OR GUARDS.



DO NOT SCALE

**American Vault**<sup>®</sup> Waco Texas

PRODUCT APPLICATION DRAWING  
700 SERIES RTS 4-1/2" UPSEND  
HOOK-UP DETAIL

SIZE	DWG NO	DATE	SHEET
<b>A</b>	20089	12.01.2023	5 OF 5





7500 Mars Drive  
Waco, TX 76712  
(254) 776-0100 P  
(254) 776-0700 F  
[www.AmericanVault.us](http://www.AmericanVault.us)

## 2 INSTALLATION

### 2.1 Unpacking and Inspection

The carton should contain the following items:

(Refer to Section 1, Drawing #20089 for contents)

### 2.2 Site Requirements

The pneumatic tube system can be installed in most existing drive thru locations. Adequate support structure is required to support the pneumatic tube above the drive thru. It is recommended that the structure be covered to protect the customer kiosk from the weather.

Electrical power can be run underground or overhead. Underground and Overhead power applications use 2 ea. 3/4" conduits. One for 115 VAC power and the other for control, CCTV, audio, low voltage power. Each lane must have (1) 15 amp circuit. This circuit supplies both the customer kiosk and the teller kiosk. The preferred method of connection is a duplex outlet in the canopy near the point where the transmission tube enters the canopy.

(Refer to Section 1, Drawing #20089 for installation)

### 2.3 Installation Procedure

The teller unit is installed by mounting the hanging bracket on the wall above the window. The G.C. should provide a header capable of supporting the weight of the teller unit to secure the bracket to the wall. The teller unit is attached to the bracket using supplied hardware.

The customer unit base is anchored to the island using 3/8" wedge anchors. The base is positioned using the supplied 30 deg. template. The base is leveled using shims then secured using the anchor bolts.

The tubing is cut and fit using standard practices.

Joints should be secured by appropriate methods to prevent vacuum loss. Tubing should be braced to prevent excessive movement and possible stresses to joints. Note: Wiring of the units is covered in section 5.3 of this manual.

### 2.4 System Interconnect Diagram

(Refer to following pages, drawing #700-1001C)

NOTES:

1. THE BRANCH CIRCUITS SUPPLYING THE 700 SERIES RTS MUST BE A DEDICATED CIRCUIT USING INDIVIDUAL HOT, NEUTRAL, AND GROUND CONDUCTORS.
2. NEITHER THE CONDUIT NOR THE NEUTRAL SHOULD BE SHARED WITH OTHER CIRCUITS.
3. CONDUIT MUST NOT BE USED IN PLACE OF GROUND WIRE.
4. CUSTOMER UNIT LOAD IS 9.0 AMPS. TELLER UNIT LOAD IS 1.0 AMP. NO OTHER LOADS ARE TO BE CONNECTED TO THIS CIRCUIT.
5. ONE BREAKER IS TO SHUT DOWN ONE SYSTEM (CUSTOMER & TELLER UNIT) ONLY.

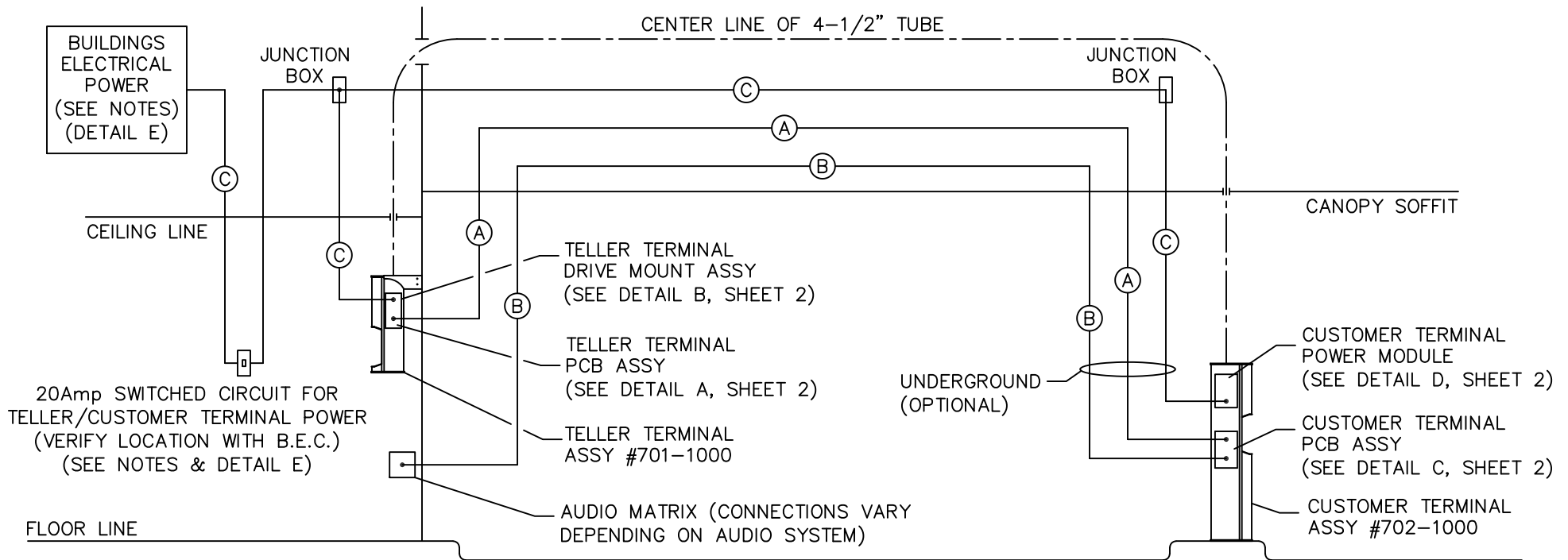

- (A) CUSTOMER/TELLER INTERFACE CABLE  
15 CONDUCTOR, 22 AWG  
AVC PART #2009-0003
- (B) AUDIO INTERFACE CABLE  
(REFER TO AUDIO SYSTEM SPEC'S)
- (C) 120Vac, 60Hz, SINGLE PHASE, 20Amp  
DEDICATED SWITCHED BRANCH CIRCUIT  
(SEE NOTES & DETAIL E)

DO NOT SCALE

**American**  
**Vault**® Waco Texas

PRODUCT APPLICATION DRAWING  
SYSTEM INTERCONNECT DIAGRAM  
700 SERIES RTS

SIZE	DWG NO	DATE	SHEET
<b>A</b>	700-1001C	11.10.2007	1 OF 2

BUILDINGS ELECTRIC  
POWER (SEE NOTES)

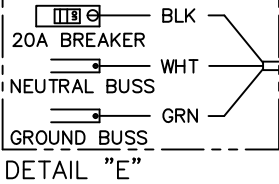

JUNCTION  
BOX

JUNCTION  
BOX

POWER CORD,  
16/3 SJOW 10' LG,  
AVC PART #2040-0003

TELLER TERMINAL

CUSTOMER TERMINAL

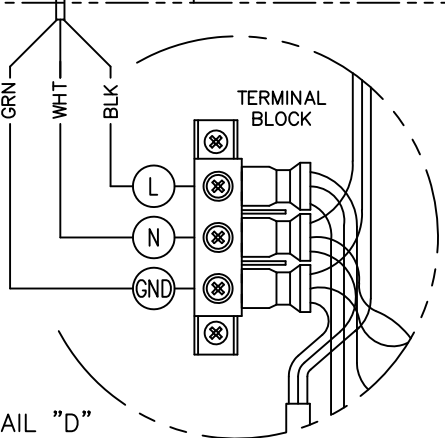
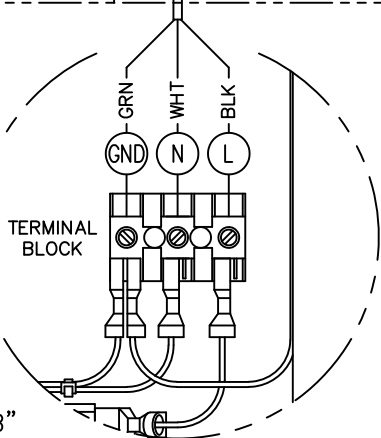

DETAIL "B"  
DRIVE MNT ASSY

DETAIL "D"  
POWER MODULE

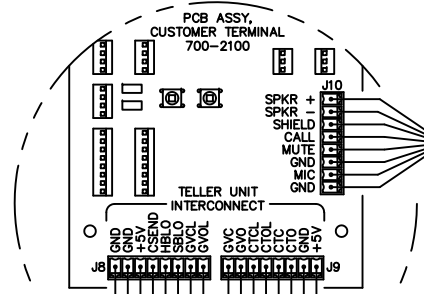
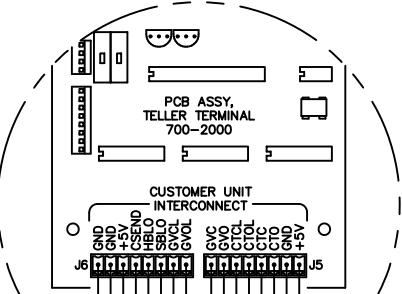

DETAIL "A"  
DRIVE MNT ASSY

DETAIL "C"  
CONTROL MODULE

- Ⓐ CUSTOMER/TELLER INTERFACE CABLE  
15 CONDUCTOR, 22 AWG  
AVC PART #2009-0003
- Ⓑ AUDIO INTERFACE CABLE  
(REFER TO AUDIO SYSTEM SPEC'S)
- Ⓒ 120Vac, 60Hz, SINGLE PHASE, 20Amp  
DEDICATED SWITCHED BRANCH CIRCUIT  
(SEE NOTES & DETAIL E)

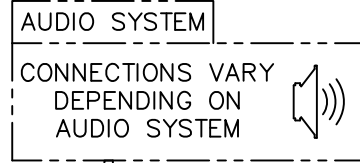

DO NOT SCALE

**American  
Vault**® Waco Texas

PRODUCT APPLICATION DRAWING  
SYSTEM INTERCONNECT DIAGRAM  
700 SERIES RTS

SIZE	DWG NO	DATE	SHEET
<b>A</b>	700-1001C	11.10.2007	2 OF 2

### 3 OPERATIONS

#### 3.1 Switches and Indicators

##### 3.1.1 Send Switch

The send switch located on the teller control panel initiates a send cycle any time the system is not in the middle of a cycle, regardless of the position of either door or the carrier.

##### 3.1.2 Home Switch

The home switch located on the teller control panel initiates a home cycle any time it is pushed, even if the system is in the middle of a cycle, and regardless of the position of any doors or the carrier.

##### 3.1.3 Tset Switch

The Tset switch located on the teller control P.C.B. initiates a travel time set sequence. This process is described further in section 3.2.4 of this manual.

##### 3.1.4 Send lamp

The send lamp, located on the send switch indicates the system status for the send function. Off indicates that the system is not in the send mode, however the send switch will be recognized. On solid indicates that the system is in the send mode and expects the next operation to be send. On flashing indicates that the system is in a send cycle and the operator should wait.

##### 3.1.5 Home lamp

The home lamp, located on the home switch indicates the system status for the home function. Off indicates that the system is not in the home mode, however the home switch will be recognized. On solid indicates that the system is in the home mode and expects the next operation to be home. On flashing indicates that the system is in a home cycle and the operator should wait.

##### 3.1.6 Customer Send Switch

The customer send switch, located on the front of the customer unit, initiates a home cycle only upon the successful completion of a teller send cycle.

##### 3.1.7 Call Switch

The call switch, located on the front of the customer unit, is part of the audio interface provided on the customer unit circuit board. Pressing this switch generates a call tone on the connected audio system.

#### 3.2 Functions

##### 3.2.1 Send

The send function is used to move the carrier from the teller position to the customer position. When this switch is pressed, the control checks the position of the customer door. If the door is not closed, a signal is generated to close it. Next, the position of the teller door is checked, if it is not fully closed, the door is closed then opened slightly. Next, the blower control valve is rotated into position. Then the send blower, located in the customer unit comes on pulling the carrier to the outside. The carrier then arrives at the customer unit. When the send blower time completes, the outside door opens. Then the teller door closes and the blower control valve moves to the home position. This completes the send cycle.

##### 3.2.2 Home

The home function is used to move the carrier from the customer position to the teller position. When this switch is pressed, the control checks the position of the customer door. If the door is not closed, a signal is generated to close it. Next, the position of the teller door is checked, if it is not fully closed, the door is closed. Next, the blower control valve is rotated into position. Then the home blower, located in the customer unit comes on pushing the carrier to the inside. The carrier then arrives at the teller unit. When the home blower time completes, the inside door opens, and the blower control valve moves to the send position. This completes the home cycle.

### 3 Operations (continued)

#### 3.2.3 Tset

This function is used to set the travel time of the carrier in both directions.

##### 3.2.3.1 Setting the send time:

1. Press home and wait for the cycle to complete.
2. Place carrier in carrier deposit chamber.
3. Press Tset switch.
4. Immediately, the send lamp will flash.
5. Wait for the send lamp to light solid.
6. Press the send switch and hold it until the carrier lands outside. This will be indicated either visually or audibly. Continue holding the send switch for about half a second after the carrier lands to ensure that the carrier will have plenty of time to get there.
7. This completes the send time setting procedure.

##### 3.2.3.2 Setting the home time:

1. Place carrier in carrier deposit chamber.
2. Press send and wait for the cycle to complete.
3. Press the Tset switch.
4. Immediately, the home lamp will flash.
5. Wait for the home lamp to light solid.
6. Press the home switch and hold it until the carrier lands inside. This will be indicated either visually or audibly. Continue holding the home switch for about half a second after the carrier lands to ensure that the carrier will have plenty of time to get there.
7. This completes the home time setting procedure.

#### 3.2.4 Customer Send

This function is used by the customer to move the carrier from the customer terminal to the teller terminal. This switch is only active after the successful completion of a send function. Once the customer send switch is recognized by the control, the sequence is identical to the home cycle.

#### 3.2.5 Recall before delivery

Recall is used to return a carrier to the teller before the customer has the chance to retrieve it. It is useful if the teller sends the wrong carrier to a lane. Recall is activated by holding the home switch during a send cycle. After the switch is held for about 1 second, the home lamp will begin flashing. This indicates that the recall is pending. When the carrier lands outside it will immediately return before the door opens. Once the customer door begins to open, the recall function will not be accepted.

#### 3.2.6 Shutdown Mode Rev 4 (blue dot) firmware only.

Shutdown mode is used to prevent air inside the bank from circulating through the tube and causing condensation. To enter shutdown mode, 'home' the system and remove the carrier. Press and hold teller 'Send'. When the send and home lights go out, you can release 'Send'. (approx. 6 seconds). The blower will time out, both doors will be closed and the home light will come on. To return to normal operation, press 'Home'. The teller door will open and the carrier can be placed into the system and sent out to the customer. There is an active and passive mode in the shutdown procedure which can be toggled by pressing the send pushbutton. The default mode is passive (send light off). Pressing the send button will light the send light and enable active mode which turns the home blower on for 20 seconds every 2 minutes to force outside air into the tube to further prevent inside air from infiltrating the system. Passive mode can result in accelerated wear to the home blower but may be required in extreme environments.



7500 Mars Drive  
Waco, TX 76712  
(254) 776-0100 P  
(254) 776-0700 F  
[www.AmericanVault.us](http://www.AmericanVault.us)

## 4 MAINTENANCE

### 4.1 Cleaning

The customer and teller units should be cleaned with a mild cleaner and a soft cloth. Any debris should be removed from the carrier deposit chambers as they could prevent proper operation of the system. Use of harsh solvents or acids could damage the finish of the system.

### 4.2 Preventative maintenance

There are no user serviceable parts in the customer or teller units and all service should be performed by authorized service personnel. The system should be serviced yearly to check the condition of drive components, and to remove any debris from the inside of the customer and teller units. The serviceman should check the motor, drive belts and rollers for signs of excessive wear, and replace if necessary.

## 5 SERVICE

### 5.1 Fault Analysis

There are indicators on the teller and customer units which help in troubleshooting the Model 700 RTS. They are outlined below.

#### 5.1.1 Teller Unit

##### 1. Send Light

This lighted switch is lit upon proper initialization of the teller unit. It indicates that the system is ready for a send operation. This switch will flash during a send cycle, signaling that the operation is currently in process.

##### 2. Home Light

This lighted switch is lit after a Send operation is complete. It indicates that a home operation is the next intended operation. This switch will flash during a home cycle, signaling that the operation is currently in process. It will also be lit during a send cycle signaling that a recall before delivery cycle can be initiated.

#### 5.1.2 Customer unit

##### 1. Send and Call Lights

Send and Call lights are lit directly from the +12 volt supply of the Teller PCB. If these lights are not on then +12VDC is not present on the outside board.

### 5.2 Pre-requisite vs. Stand-alone functions

The functions of the Model 700 RTS can be divided into two groups. Stand alone functions and pre-requisite functions.

5.2.1 Stand-alone functions are those that don't require certain conditions for operation. These include the following:

1. Teller Send
2. Teller Home
3. Teller and Customer door operations
4. Diverter valve operation

5.2.2 Pre-requisite operations are those that require that certain conditions exist in order to complete properly. These include:

##### 1. Home Blower

Teller and Customer door closed limit switches must remain activated in order for the home blower cycle to complete. If either door opens, the blower cycle will end immediately. If either door fails to close, the blower cycle will be skipped.

##### 2. Send Blower

Customer door closed limit switch must remain activated in order for the send blower cycle to complete. If customer door opens, the blower cycle will end immediately. If customer door fails to close, the blower cycle will be skipped.

##### 3. Customer Send

Customer Send is only active after the completion of a Teller Send cycle.

#### 5.2.3 TSET

TSET is a status conditional operation. If the teller send switch is lit, pressing the TSET button will initiate a send time set sequence. If the teller home switch is lit, pressing the tset button will initiate a home time set sequence.

## 5 SERVICE (continued)

### 5.3 Field Wiring

- +V

+12VDC on later boards +5VDC on 700-2000 Rev 2 and earlier supplies power for customer pushbutton lights and CSND customer send function.

- GND Control Common
- CTO Customer Terminal Open

A positive voltage on this wire will cause the customer door to open. 0 VDC inactive, 10 VDC active

- CTC Customer Terminal Close

A positive voltage on this wire will cause the customer door to close. 0 VDC inactive, 10 VDC active

- CTOL Customer Terminal Open Limit

The teller board holds this wire at 10 VDC. The customer open limit switch pulls this wire to GND when the door is fully open.

If this circuit fails OPEN, the door will chatter for a few seconds when the limit is reached but the system will otherwise function. If this circuit fails closed, the door will not open because the teller board thinks it already is fully open.

- CTCL Customer Terminal Close Limit

The teller board holds this wire at 10 VDC. The customer close limit switch pulls this wire to GND when the door is fully closed.

If this circuit fails OPEN, the door will chatter for a few seconds when the limit is reached and the blower motor will not turn on. If this circuit fails closed, the door will not close because the teller board thinks it already is fully open.

The blower will come on but with the door open, the carrier will not travel.

- GVO Gate Valve Open

A positive voltage on this wire will cause the home blower port to open and the send blower port to close. 0 VDC inactive, 10 VDC active

- GVC Gate Valve Close

A positive voltage on this wire will cause the home blower port to close and the send blower port to open. 0 VDC inactive, 10 VDC active

- GVOL Gate Valve Open Limit

The teller board holds this wire to 10 VDC. The gate valve open limit switch pulls this wire to GND when the gate valve is fully in the Home position.

If this circuit fails Open circuit, the valve will chatter against the Open limit for a few seconds but the unit will otherwise function. If this circuit fails in the shorted condition, the valve will not move to the open position because the teller controller will think it is already in position

- GVCL Gate Valve Close Limit

The teller board holds this wire to 10 VDC. The gate valve close limit switch pulls this wire to GND when the gate valve is fully in the Send position.

If this circuit fails in the Open circuit condition, the valve will chatter against the Open limit for a few seconds but the unit will otherwise function. If this circuit fails in the shorted condition, the valve will not move to the closed position because the teller controller will think it is already in position





## 5 SERVICE (continued)

### 5.3 Field Wiring (continued)

- SBLO Send Blower

This wire is normal 0 VDC. When the teller turns on the blower, this wire goes to approx 10 VDC to turn on the blower motor

- HBLO Home Blower

This wire is normal 0 VDC. When the teller turns on the blower, this wire goes to approx 10 VDC to turn on the blower motor

- CSND Customer Send

On all systems prior to teller board 700-2000 Rev C. This signal is normally at the GND voltage and changes to near V+ when the customer send pushbutton is pressed.

On boards 700-2000 Rev C and later, this polarity is settable by jumper JP1 & JP2 on the teller board. JP1 is shorted if the customer board is a 700-2000 rev. C otherwise JP2 is shorted. The 700-2100 Rev C customer board has 1 jumper, JP3 it should only have a jumper installed if it is being used with a 700-2000 Rev. C teller board.

- +V Positive Voltage

+12VDC on later boards +5VDC on 700-2000 Rev 2 and earlier. Supplies power for customer pushbutton lights and CSND customer send function.

- GND Control Common
- GND Control Common

#### 5.3.1 Field wiring indicators (700-2000 Rev C only)

The Rev C teller board has indicator led's to help diagnose problems with the customer/teller interface. These correspond with the wire directly below the LED. If the CTO, CTC, GVO, GVC, SBLO, HBLO led's are lit then the customer motor corresponding to that function should be running. If the CTOL, CTCL, GVOL, GVCL led's are lit then that corresponding limit switch should be made. The CSND led should light any time the Customer send pushbutton is pressed.

### 5.4 Troubleshooting Guide

<b>Symptom: Unit Will Not Power-Up</b>	
<b>Checks</b>	<b>Corrective Action</b>
110 VAC Power	Check 110 VAC Power to teller and customer units.
12 VDC Power	Check for Send and Call pushbutton lights on the customer unit. These work directly off of 12 VDC and should always be on.
Field wiring	Disconnect field wiring from the teller end. Power up teller end. If the door opens and the send light lights up then there is a crossed wire or a short in the field wiring or the customer board is shorting out the 5 volt supply.
Fuses	Fuses on the teller and customer board are self resetting provided that the over current condition has been cleared.
Wiring	Check wiring harness on teller board and between customer and teller units.
Teller Board	Check for damaged connectors, traces or components on the teller board



**5 SERVICE (continued)**

5.4 Troubleshooting Guide (continued)

<b>Symptom: Blower Control Valve Does Not Operate</b>	
<b>Checks</b>	<b>Corrective Action</b>
Check valve for free movement up & down	Remove the motor with its mounting plate from the blower assembly. Make sure the valve spool can be moved up & down freely. If the spool is not free, remove it and check for debris or burrs.
Actuator Arm	The Actuator Arm on the valve assembly should move freely. Make Shoulder Screws are not binding in slots
Power	Ensure that 120 VAC power is present at the Customer board. this may be checked with a DVM at TB1
Relays	You should not attempt to measure the relays directly because of the possibility of damage however you can measure the voltage on the field wiring. This is the terminal marked GVO gate valve open, and GVC gate valve close. This voltage should be 0 volts normally and about 1.1 volts when operating. If this voltage exceeds 4.5 volts when operating, the relay for the related function is defective. In order to check the output side of the relay you will have to complete the above step to prove the input is working then substitute a known good board. If the motor still does not work then the board should be replaced.
Gear motor	See gear motor section

<b>Symptom: Blowers Do Not Come On</b>	
<b>Checks</b>	<b>Corrective Action</b>
Blower Signal	Monitor the voltage on the field wiring terminals marked SBLO 'send blower' and HBLO 'home blower'. The voltage should be 0 normally and will go to five volts nominally when the blower signal is present
Power	Verify that blowers are connected to 110 VAC power.
Wiring	Check wiring for proper connection and continuity.
Blower Motor	Measure the AC voltage across the load side of the relay when the blower motors are not running. If this voltage is less than the 120 VAC supply voltage, the motor brushes are likely worn out. You may also check the blower motor by bypassing solid state relay and powering the motor directly. You MUST disconnect power while rewiring blower. Failure to do so could result in injury or death.
Door positions	In order for the blowers to be turned on, the doors must be closed. If the controller doesn't recognize that the doors are closed, the blowers will not turn on. This could be caused from defective door motors, defective door limit switches, wiring problems or a defective microcontroller.
Solid State Relay	The solid state relay can be checked by the process of elimination. If you verify that the blower signal is present and verify the operation of the blower motor, it can be assumed that the relay is defective.



**5 SERVICE (continued)**

5.4 Troubleshooting Guide (continued)

<b>Symptom: Customer or Teller Door Will Not Operate</b>	
<b>Checks</b>	<b>Corrective Action</b>
Check door for freedom of movement	Remove the drive plate from the unit. Make sure the door can move up and down freely. The door should slide down by its own weight.
Door seal	Ensure that the top seal of the door is not stuck to the casting. If so, light oil should prevent future adhesion.
Power	Ensure that 120 VAC power is present at the Customer board. this may be checked with a DVM at TB1
Relays	You should not attempt to measure the relays directly because of the possibility of damage however you can measure the voltage on the field wiring. This is the terminal marked CTO customer terminal open, and CTC customer terminal close. This voltage should be 0 volts normally and about 1.1 volts when operating. If this voltage exceeds 4.5 volts when operating, the relay for the related function is defective. In order to check the output side of the relay you will have to complete the above step to prove the input is working then substitute a known good motor. If the motor works then the Solid State relay is defective.
Limit Switches	Make sure that the limit switch connections are good and that the switch has continuity. Check the limit switch 'away' from the door drive block. If this switch is defective the door won't move to it.
Wiring	Check all wiring and connections in the limit switch and motor harness. Check closely for damaged contacts in the connectors which may appear OK but may not be making contact.
Gear motor	The motor lead resistance should be 1,660 Ohms nominally from black to blue and red to blue. There should be no continuity from red to case, red to black or black to case. If motor is running but the output shaft is not turning, the gearbox may be defective.