

**MODEL 552-6**  
(6) 5x16 OPENINGS

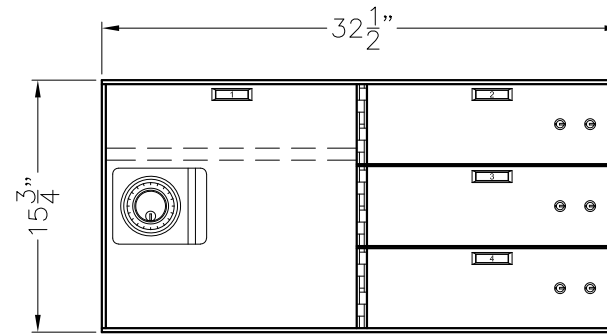

**MODEL 552-1/3**  
(1) 15x16 OPENING  
WITH ADJ SHELF  
(3) 5x16 OPENINGS

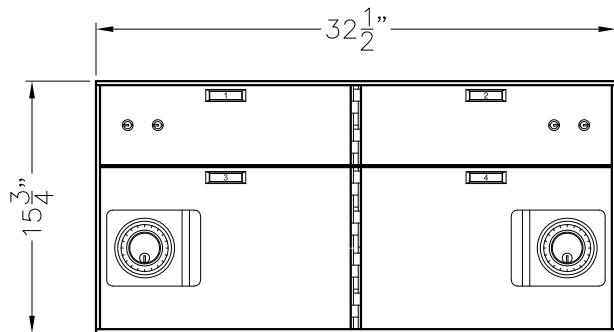

**MODEL 552-2/2**  
(2) 5x16 OPENINGS  
(2) 10x16 OPENINGS

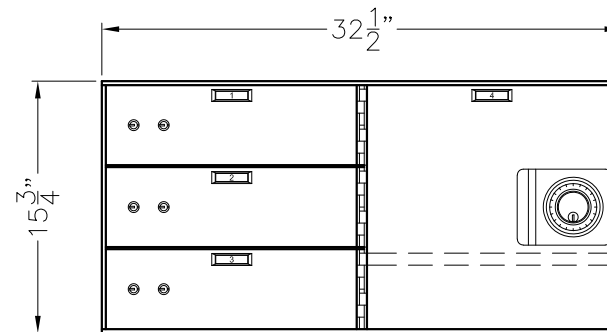

**MODEL 552-3/1**  
(3) 5x16 OPENINGS  
(1) 15x16 OPENING  
WITH ADJ SHELF

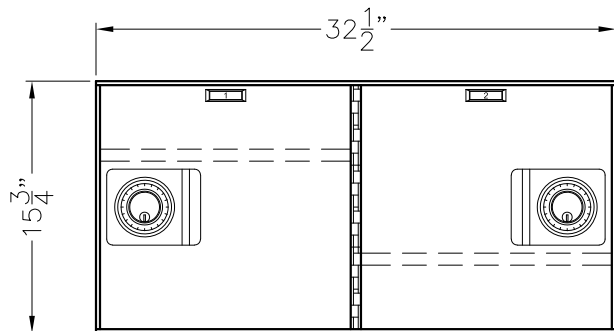

**MODEL 560-2**  
(2) 15x16 OPENINGS  
WITH ADJ SHELVES

- SECTION SIZE: 15-3/4" HIGH x 32-1/2" WIDE x 18" OR 24" DEEP
- CONSTRUCTION: REINFORCED COATED STEEL CASE, ANODIZED ALUMINUM FRONT FRAME
- COMBINATION LOCKS: GROUP 2, 3 WHEEL, WITH KEY-LOCKING DIAL AND RING
- SAFE DEPOSIT LOCKS: UNIVERSAL, DOUBLE NOSE, FIXED/FIXED, FINISHED IN BRASS
- HINGES: FRAME INTERLOCKING, FINISHED IN BRASS
- DOORS: MACHINED FROM SOLID ALUMINUM ALLOY, FINISHED WITH STAINLESS STEEL
- NUMBER STRIPS: BLACK CHARACTERS ON A BRASS TONE BACKGROUND SET IN A FRAME WHICH COMPLEMENTS THE STAINLESS STEEL DOOR FRONT PLATE

DO NOT SCALE

**American**  
**vault**® Waco Texas

PRODUCT APPLICATION DRAWING  
500 SERIES LOCKERS  
MODEL 552 & 560 (15-3/4")

SIZE	DWG NO	DATE	SHEET
<b>A</b>	20061-552	12.01.2023	1 OF 1